

Air Heaters

Air Heaters	Sheath Materials	Max. Operating Temperatures		Typical Max. Watt Densities		Page
		°F	°C	W/in ²	W/cm ²	
Duct Heaters						
LDH SERIES and D SERIES	Incoloy®	1200	650	30	4.7	427
MDH SERIES	Incoloy®	1200	650	26	4.0	441
Finned						
375 Finned Strip	Aluminized steel	1100	595	33	5.1	445
FINBAR™ Single/ Double-Ended	304 stainless steel	1200	650	50	7.7	451
FIREROD® Cartridge	Incoloy®	Application Specific		100	15.5	452
Enclosure Heaters						
WATROD™	Incoloy®	390	200	15	2.3	453
Silicone Rubber	Fiberglass reinforced silicone rubber	500	260	5	0.8	455





Air Heaters

Duct Heaters

LDH SERIES and D SERIES

Constructed of sturdy 0.430 in. (11 mm) diameter WATROD™ heating elements mounted to a ¼ in. (6 mm) thick steel flange, duct heaters are easily adapted to many non-pressurized air-heating systems.

They are easily installed in applications requiring a wide range of temperature versus air flow combinations.

The modular duct heater offers increased reliability. The individual modules are removable through the housing of the assembly, which eliminates the need to pull the complete heater from the ductwork. This reduces downtime costs because the heating elements can be replaced individually. Performance improvements include quicker response time and reduced infiltration from the air stream being heated into the electrical enclosure.

Watlow® duct heaters offer advantages over gas or oil fired and open coil electric units with:

- Installation flexibility—no flues or fuel lines
- 100 percent energy efficient—no energy loss up the flue
- Universal availability of electricity
- Resistance coil in Incoloy® sheath is protected from corrosive environments

Performance Capabilities

- Watt densities to 40 W/in² (6.2 W/cm²)
- Recommended process temperatures from -20 to 1200°F (-7 to 650°C)
- Catalog P/N wattages to 225kW
- Voltages to 600VAC

Features and Benefits

Long life Incoloy® sheath

- Resists corrosion/oxidation while protecting resistance coils against contamination

MgO insulation filled elements compacted to rock hard density

- Maximizes dielectric strength, heat transfer and life

Field replaceable heating elements

- Permits easy service and reduces downtime. Element change-out is made simple by a single screw clamp (D SERIES only)

3½ in. (90 mm) thick mineral insulation

- Keeps wiring cooler and reduces heat loss

Silicone resin seals rated to 221°F (105°C)

- Protects elements against moisture and other contaminants

General purpose terminal enclosure

- Offers easy access to wiring

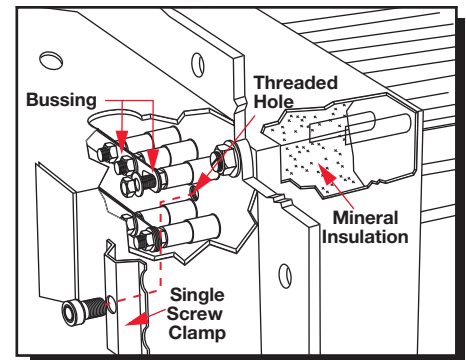
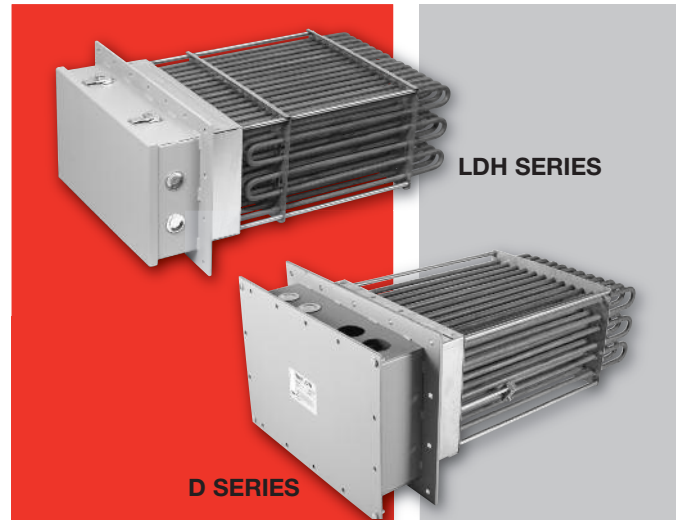

¼ in. (6 mm) inside diameter thermowell

- Accepts an optional Type J or K thermocouple for accurate sheath temperature sensing (D SERIES only)

Rigid stainless steel supports

- Prevents element sagging or deformation in various mounting positions

¼ in. (6 mm) thick steel flange with ⅝ in. (9.5 mm) diameter mounting holes

- Easily bolts to the duct wall

WATROD hairpins are repressed (recompacted) after bending to assure MgO density

- Eliminates hot spots and electrical insulation voids

Stock heaters feature from 3 to 60 elements

- Meets a wide variety of kilowatt demands

One or three phase voltages

- Meets local power supplies

Maximum 48 amperes per circuit

- Complies with National Electrical Code (NEC)

Duct heaters with general purpose enclosures meet UL® and CSA component recognition to 480 and 600VAC maximum respectively—UL® and CSA file numbers are E52951 and 31388

RAPID SHIP

- Same day shipment up to two pieces

Air Heaters

Duct Heaters

LDH SERIES and D SERIES

Typical Applications

- Drying ovens
- Autoclaves
- Furnaces
- Load banks
- Heat treating
- Reheating
- HVAC
- Paint drying

Choosing a Duct Heater

The English and metric graphs, shown on the following pages will help you to select the correct duct heater. These graphs include: *Watt Density vs. Air Temperature/Velocity*, *Watt Density vs. Sheath Temperature and Pressure Drop vs. Air Velocity*.

These graphs, with the quick formulas on this page, along with information specific to your application, will determine the correct duct heater specifications. However, if engineering assistance is needed, contact your Watlow representative.

Required Application Information

- Desired outlet air temperature
- Inlet air temperature
- Delta T—the temperature difference between inlet and desired outlet temperature
- Air volume (CFM/CMM) measured at both inlet temperature and pressure
- Air velocity in feet per minute (FPM); meters per minute (MPM) which equals:

English	
$FPM =$	$\frac{CFM \text{ measured at standard conditions}}{\text{Duct cross section area at heater in ft}^2}$
Metric	
$MPM =$	$\frac{CMM \text{ measured at normal conditions}}{\text{Duct cross section area at heater in m}^2}$

- Minimum duct heater wattage (kW). This can be determined by:

English	
$kW =$	$\frac{CFM \times \text{Delta T } (^{\circ}F) \times 1.1 \text{ (safety factor)}}{3000}$
Metric	
$kW =$	$\frac{CMM \times \text{Delta T } (^{\circ}C) \times 1.1 \text{ (safety factor)}}{48}$

Note: The duct heater, or combination of duct heaters, used for the process should be equal to or exceed the minimum wattage calculation.

Air Heaters

Duct Heaters

LDH SERIES and D SERIES

Watt Density vs. Air Temperature/Velocity

To decide watt density requirements, first determine the desired outlet air temperature and velocity in feet per minute. Then, follow the lines on the graph for velocity and process temperature to the watt density curve's

intersecting point. This shows the recommended watt density based on a maximum sheath temperature of 1400°F (760°C). **For longer heater life, lower watt densities should be chosen.**

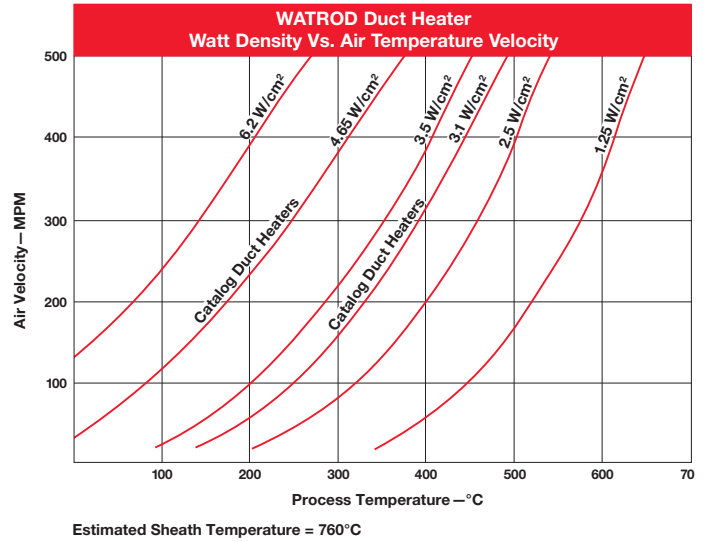
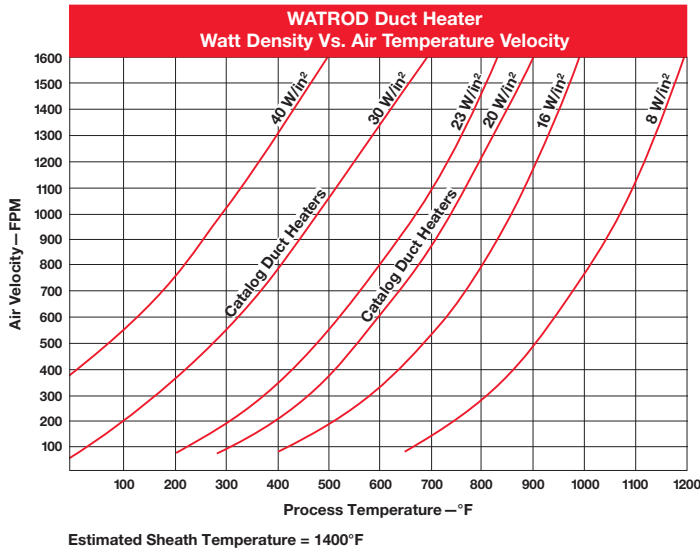

Watt Density vs. Sheath Temperature

The *Watt Density vs. Sheath Temperature* graph shows the air velocity (FPM or MPM) required to operate a WATROD duct heater at specific watt densities or sheath temperatures. Also depicted is the appropriate watt density vs. sheath temperature at a specified air flow.

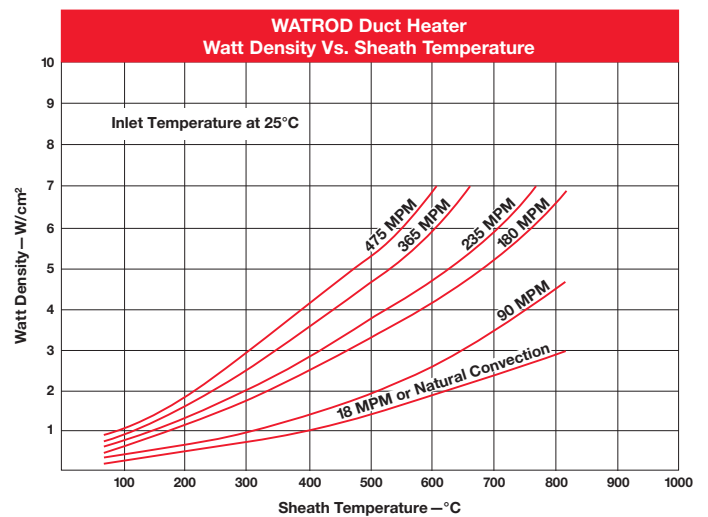
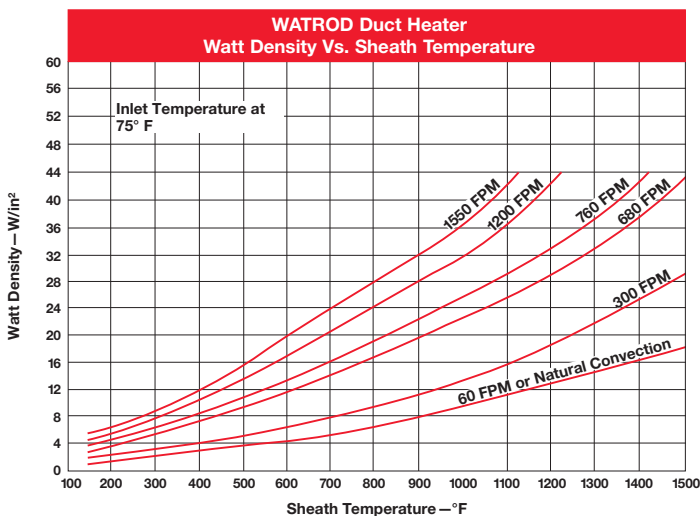

Air Heaters

Duct Heaters

LDH SERIES and D SERIES

Pressure Drop vs. Air Velocity

The rate at which pressure drops through the duct heater is critical for properly sizing blowers and pumps. *The Pressure Drop vs. Air Velocity* graph gives recommended maximum velocities in feet per minute and meters per minute according to the air velocity and duct heater size.

To determine the pressure drop through the duct heater, follow the air velocity (FPM or MPM) over to the appropriate curve, which identifies the duct heater size. Then, take the intersecting point down to the approximate pressure drop value.

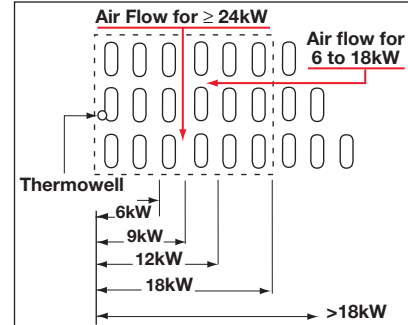

Note: Viewing from the element ends—the recommended air flow direction through element bundle changes at >18kW.

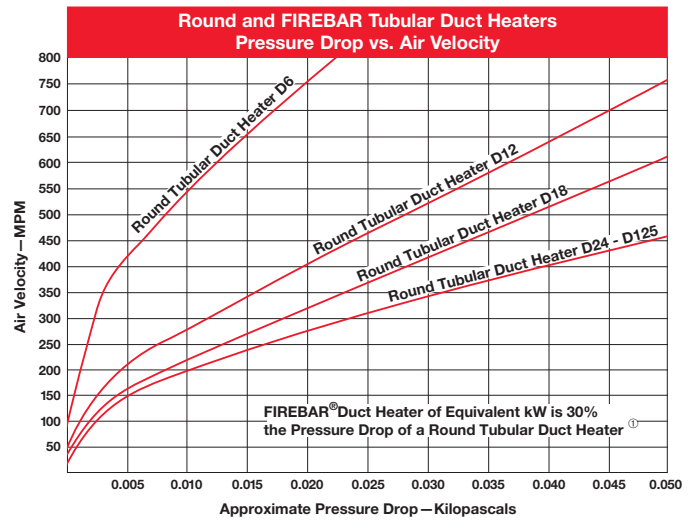
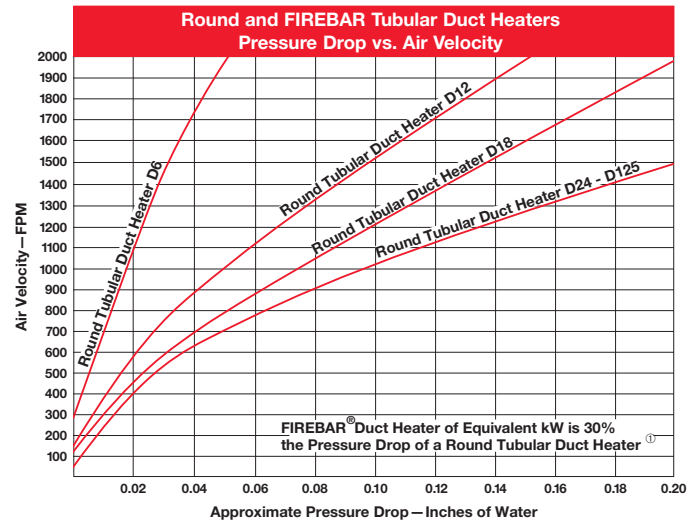

① FIREBAR® flat tubular element duct heaters are available as extended capabilities to enhance your application output or performance. Although duct heaters are not normally constructed with FIREBAR elements, the pressure drop reduction using FIREBAR as a distinct advantage is shown above.

Options

Wattages/Voltages

To meet specific application needs, voltage and wattage combinations outside stock product parameters are available.

For more information about this option, contact your Watlow representative.

Air Heaters

Duct Heaters

LDH SERIES and D SERIES

Options (Continued)

Terminal Enclosures

In addition to the standard, general purpose (NEMA 1) terminal enclosure, Watlow offers the following optional terminal enclosures to meet specific application requirements:

- Moisture resistant (NEMA 4)
- Stainless steel corrosion resistant (NEMA 4X—contact your Watlow representative)
- Dust resistant (NEMA 12)

Thermocouples

Type J or **K** thermocouples, inserted in the thermowell, accurately sense element sheath temperature for over-temperature conditions.

To sense process temperature, the sensing element should be located downstream from the duct heater. This will eliminate incorrect sensing caused by radiant heat.

Thermocouples are supplied with 120 in. (3050 mm) leads, longer lead lengths are available (this applies to “D” SERIES only). Unless otherwise specified, thermocouples are supplied with temperature ranges detailed on the *Thermocouple Types* chart.

Using a thermocouple requires an appropriate temperature and power controller. These must be purchased separately. Watlow offers a wide variety of temperature and power controllers to meet virtually all applications. Temperature controllers can be configured to accept process variable inputs, too. Contact your Watlow representative for details.

To order a thermocouple, add the appropriate suffix letter to the duct heater’s base code number, as indicated on the *Build-a-Code* chart on page 440.

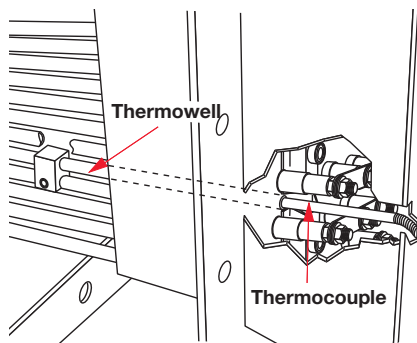

Duct heater thermowell holds thermocouple for sensing sheath temperature.

Thermocouple Types

ASTM Type	Conductor Characteristics		Recommended ^① Temperature Range	
	Positive	Negative	°F	(°C)
J	Iron (Magnetic)	Constantan (Non-magnetic)	0 to 1000	(-20 to 540)
K	Chromel® (Non-magnetic)	Alumel® (Magnetic)	0 to 2000	(-20 to 1100)

① **Type J** and **Type K** thermocouples are rated 32 to 1382°F and 32 to 2282°F (0-750°C and 0-1250°C), respectively. Watlow does not recommend exceeding temperature ranges shown on this chart for the tubular product line.

Application Hints

- Mount duct heaters horizontally to lower enclosure temperatures and promote unit life.
- Orient heating elements as per the air flow illustration on page 430.
- Promote heater life by keeping sheath temperature below the 1400°F (760°C) maximum.
- Measure process temperature in the outlet stream, away from the heater.
- Maintain wiring integrity by keeping enclosure temperature below 400°F (205°C).
- Thermal cycling can cause terminations to loosen. Periodically check and tighten all electrical connections.
- Size power feeder wires in accordance with NEC and other applicable codes.
- Protect employees against electrical shock by properly grounding the unit per NEC specifications.

Extended Capabilities For Duct Heaters

LDH SERIES and D SERIES

Performance Capabilities

- Wattages to 2.2 megawatts

Features and Benefits

Ceramic fiber insulation available

- Keeps wiring cooler and reduces heat loss

Greater than ¼ in. (6 mm) with 304 or 316 stainless steel flange material

- Easily bolts to the duct wall

60 plus element designs available

- Meets a wide variety of kilowatt demands

Options

Sheath Material

Watlow duct heaters can be made with the following sheath materials:

- 316 SS
- Alloy 400 and 600
- Laminated Alloy 600 (hi-temp)
- Hastelloy C276

Contact your Watlow representative for details and availability.

Terminal Enclosures

In addition to the standard, general purpose (NEMA 1) terminal enclosure, Watlow offers the following optional terminal enclosures to meet specific application requirements:

- Explosion resistant (NEMA 7—contact your Watlow representative)
- High-temperature stand-off enclosures

Air Heaters

Duct Heaters

LDH SERIES

Application: High Temperature Air 800°F (427°C)

- Welded Incoloy® WATROD elements
 - Without thermostat
 - General purpose enclosure
 - Steel flange
- ① 3 and 6 element heaters have (1) 1 inch NPT conduit opening; 9, 12 and 15 element heaters have (2) 1 inch NPT conduit openings; 18 element heaters have (2) 1½ inch NPT conduit openings; 21 element (B= 20¼ in.) heaters have (2) 1½ inch NPT conduit openings; remaining 21 and 24 element heaters have (3) 1½ inch NPT conduit openings
- ② All flanges are 12 inches wide

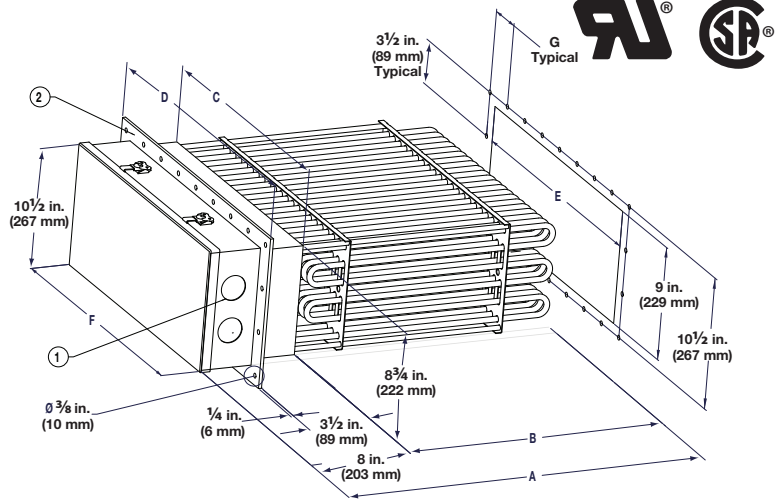

# of Elem	Volts	kW	Ph	# Circ	Code Number	Del.	Ship Wt. lbs (kg)	"A" Dim. in. (mm)	"B" Dim. in. (mm)	"C" Dim. in. (mm)	"D" Dim. in. (mm)	"E" Dim. in. (mm)	"F" Dim. in. (mm)	"G" Dim. in. (mm)
20 W/in² (3.1 W/cm²)														
3	240	9.0	1	1	LDH9S10S	RS	55 (25)	28¼ (718)	20¼ (514)	3¼ (95)	7½ (191)	4 (102)	4¼ (117.5)	3 (76)
3	240	9.0	3	1	LDH9S3S	RS	55 (25)	28¼ (718)	20¼ (514)	3¼ (95)	7½ (191)	4 (102)	4¼ (117.5)	3 (76)
3	480	9.0	1	1	LDH9S11S	RS	55 (25)	28¼ (718)	20¼ (514)	3¼ (95)	7½ (191)	4 (102)	4¼ (117.5)	3 (76)
3	480	9.0	3	1	LDH9S5S	RS	55 (25)	28¼ (718)	20¼ (514)	3¼ (95)	7½ (191)	4 (102)	4¼ (117.5)	3 (76)
6	240	18.0	1	2	LDH18S10S	RS	65 (30)	28¼ (718)	20¼ (514)	6¼ (171)	10¼ (267)	7 (178)	7¼ (193.7)	3 (76)
6	240	18.0	3	1	LDH18S3S	RS	65 (30)	28¼ (718)	20¼ (514)	6¼ (171)	10¼ (267)	7 (178)	7¼ (193.7)	3 (76)
6	480	18.0	1	1	LDH18S11S	RS	65 (30)	28¼ (718)	20¼ (514)	6¼ (171)	10¼ (267)	7 (178)	7¼ (193.7)	3 (76)
6	480	18.0	3	1	LDH18S5S	RS	65 (30)	28¼ (718)	20¼ (514)	6¼ (171)	10¼ (267)	7 (178)	7¼ (193.7)	3 (76)
9	240	27.0	1	3	LDH27S10S	RS	120 (55)	28¼ (718)	20¼ (514)	9¼ (248)	13¼ (343)	10 (254)	10¼ (269.9)	3 (76)
9	240	27.0	3	3	LDH27S3S	RS	120 (55)	28¼ (718)	20¼ (514)	9¼ (248)	13¼ (343)	10 (254)	10¼ (269.9)	3 (76)
9	480	27.0	1	3	LDH27S11S	RS	120 (55)	28¼ (718)	20¼ (514)	9¼ (248)	13¼ (343)	10 (254)	10¼ (269.9)	3 (76)
9	480	27.0	3	1	LDH27S5S	RS	120 (55)	28¼ (718)	20¼ (514)	9¼ (248)	13¼ (343)	10 (254)	10¼ (269.9)	3 (76)
12	240	36.0	1	4	LDH36S10S	RS	135 (62)	28¼ (718)	20¼ (514)	12¼ (324)	16¼ (419)	13 (330)	13¼ (346.1)	3 (76)
12	240	36.0	3	2	LDH36S3S	RS	135 (62)	28¼ (718)	20¼ (514)	12¼ (324)	16¼ (419)	13 (330)	13¼ (346.1)	3 (76)
12	480	36.0	1	2	LDH36S11S	RS	135 (62)	28¼ (718)	20¼ (514)	12¼ (324)	16¼ (419)	13 (330)	13¼ (346.1)	3 (76)
12	480	36.0	3	1	LDH36S5S	RS	135 (62)	28¼ (718)	20¼ (514)	12¼ (324)	16¼ (419)	13 (330)	13¼ (346.1)	3 (76)
15	240	45.0	3	5	LDH45S3S	RS	195 (89)	28¼ (718)	20¼ (514)	15¼ (400)	19¼ (495)	16 (406)	17¼ (454.0)	3 (76)
15	480	45.0	1	3	LDH45S11S	RS	195 (89)	28¼ (718)	20¼ (514)	15¼ (400)	19¼ (495)	16 (406)	17¼ (454.0)	3 (76)
15	480	45.0	3	5	LDH45S5S	RS	195 (89)	28¼ (718)	20¼ (514)	15¼ (400)	19¼ (495)	16 (406)	17¼ (454.0)	3 (76)
18	240	54.0	3	3	LDH54S3S	RS	205 (93)	28¼ (718)	20¼ (514)	18¼ (476)	22¼ (572)	19 (483)	20¼ (530.2)	3 (76)
18	480	54.0	1	3	LDH54S11S	RS	205 (93)	28¼ (718)	20¼ (514)	18¼ (476)	22¼ (572)	19 (483)	20¼ (530.2)	3 (76)
18	480	54.0	3	2	LDH54S5S	RS	205 (93)	28¼ (718)	20¼ (514)	18¼ (476)	22¼ (572)	19 (483)	20¼ (530.2)	3 (76)
21	240	63.0	3	7	LDH63S3S	RS	235 (107)	28¼ (718)	20¼ (514)	21¼ (552)	25¼ (848)	22 (559)	23¼ (606.4)	3 (76)
21	480	63.0	1	3	LDH63S11S	RS	235 (107)	28¼ (718)	20¼ (514)	21¼ (552)	25¼ (848)	22 (559)	23¼ (606.4)	3 (76)
21	480	63.0	3	7	LDH63S5S	RS	235 (107)	28¼ (718)	20¼ (514)	21¼ (552)	25¼ (848)	22 (559)	23¼ (606.4)	3 (76)
21	240	79.0	3	7	LDH79S3S	RS	260 (118)	33 (838)	25 (635)	21¼ (552)	25¼ (848)	22 (559)	23¼ (606.4)	3 (76)
21	480	79.0	1	7	LDH79S11S	RS	260 (118)	33 (838)	25 (635)	21¼ (552)	25¼ (848)	22 (559)	23¼ (606.4)	3 (76)
21	480	79.0	3	7	LDH79S5S	RS	260 (118)	33 (838)	25 (635)	21¼ (552)	25¼ (848)	22 (559)	23¼ (606.4)	3 (76)
21	240	105.0	3	7	LDH105S3S	S	290 (132)	40¼ (1029)	32¼ (826)	21¼ (552)	25¼ (848)	22 (559)	23¼ (606.4)	3 (76)
21	480	105.0	1	7	LDH105S11S	RS	290 (132)	40¼ (1029)	32¼ (826)	21¼ (552)	25¼ (848)	22 (559)	23¼ (606.4)	3 (76)
21	480	105.0	3	7	LDH105S5S	RS	290 (132)	40¼ (1029)	32¼ (826)	21¼ (552)	25¼ (848)	22 (559)	23¼ (606.4)	3 (76)
21	480	131.0	3	7	LDH131S5S	S	310 (141)	49¼ (1257)	41¼ (1054)	21¼ (552)	25¼ (848)	22 (559)	23¼ (606.4)	3 (76)
24	480	150.0	3	4	LDH150S5S	S	330 (150)	49¼ (1257)	41¼ (1054)	24¼ (629)	28¼ (724)	25 (635)	26¼ (682.6)	3 (76)

RAPID SHIP

- RS - Next day shipment up to 2 pieces
- S - 10 days lead time

Notes:

- See Watt Density vs. Air Temperature/Velocity charts on page 429 to confirm suitability in the application.
- Truck Shipment only

Air Heaters

Duct Heaters

LDH SERIES



Application: Medium Temperature Air 750°F (399°C)

- Welded Incoloy® WATROD elements
 - Without thermostat
 - General purpose enclosure
 - Steel flange
- ① 3 and 6 element heaters have (1) 1 inch NPT conduit opening; 9, 12 and 15 element heaters have (2) 1 inch NPT conduit openings; 18 element heaters have (2) 1½ inch NPT conduit openings; 21 element (B= 20¼ in.) heaters have (2) 1½ inch NPT conduit openings; remaining 21 and 24 element heaters have (3) 1½ inch NPT conduit openings
- ② All flanges are 12 inches wide

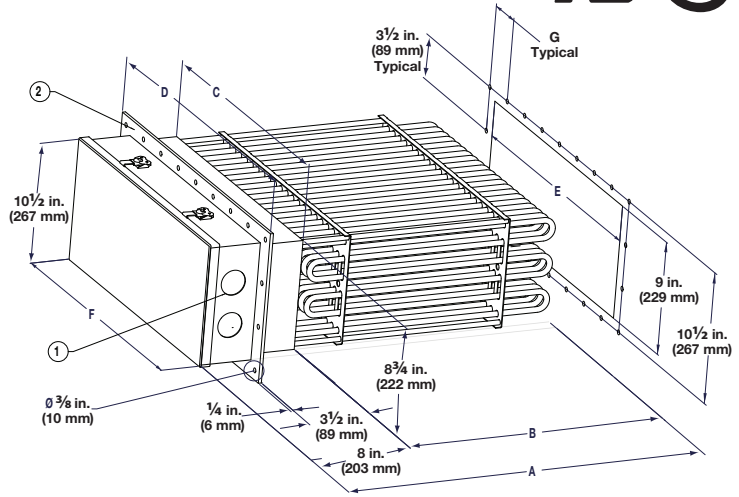

# of Elem	Volts	kW	Ph	# Circ	Code Number	Del.	Ship Wt. lbs. (kg)	"A" Dim. in. (mm)	"B" Dim. in. (mm)	"C" Dim. in. (mm)	"D" Dim. in. (mm)	"E" Dim. in. (mm)	"F" Dim. in. (mm)	"G" Dim. in. (mm)
30 W/in² (4.7 W/cm²)														
3	240	14.0	1	3	LDH14SX10S	RS	55 (25)	28¼ (718)	20¼ (514)	3¾ (95)	7½ (191)	4 (102)	4¾ (117.5)	3 (76)
3	240	14.0	3	1	LDH14SX3S	RS	55 (25)	28¼ (718)	20¼ (514)	3¾ (95)	7½ (191)	4 (102)	4¾ (117.5)	3 (76)
3	480	14.0	1	1	LDH14SX11S	RS	55 (25)	28¼ (718)	20¼ (514)	3¾ (95)	7½ (191)	4 (102)	4¾ (117.5)	3 (76)
3	480	14.0	3	1	LDH14SX5S	RS	55 (25)	28¼ (718)	20¼ (514)	3¾ (95)	7½ (191)	4 (102)	4¾ (117.5)	3 (76)
6	240	27.0	1	3	LDH27SX10S	RS	65 (30)	28¼ (718)	20¼ (514)	6¾ (171)	10½ (267)	7 (178)	7¾ (193.7)	3 (76)
6	240	27.0	3	2	LDH27SX3X	RS	65 (30)	28¼ (718)	20¼ (514)	6¾ (171)	10½ (267)	7 (178)	7¾ (193.7)	3 (76)
6	480	27.0	1	2	LDH27SX11S	RS	65 (30)	28¼ (718)	20¼ (514)	6¾ (171)	10½ (267)	7 (178)	7¾ (193.7)	3 (76)
6	480	27.0	3	1	LDH27SX5S	RS	65 (30)	28¼ (718)	20¼ (514)	6¾ (171)	10½ (267)	7 (178)	7¾ (193.7)	3 (76)
9	240	41.0	3	3	LDH41SX3S	RS	120 (55)	28¼ (718)	20¼ (514)	9¾ (248)	13½ (343)	10 (254)	10¾ (269.9)	3 (76)
9	480	41.0	1	3	LDH41SX11S	RS	120 (55)	28¼ (718)	20¼ (514)	9¾ (248)	13½ (343)	10 (254)	10¾ (269.9)	3 (76)
9	480	41.0	3	3	LDH41SX5S	RS	120 (55)	28¼ (718)	20¼ (514)	9¾ (248)	13½ (343)	10 (254)	10¾ (269.9)	3 (76)
12	240	54.0	3	4	LDH54SX3S	RS	135 (62)	28¼ (718)	20¼ (514)	12¾ (324)	16½ (419)	13 (330)	13¾ (346.1)	3 (76)
12	480	54.0	1	3	LDH54SX11S	RS	135 (62)	28¼ (718)	20¼ (514)	12¾ (324)	16½ (419)	13 (330)	13¾ (346.1)	3 (76)
12	480	54.0	3	2	LDH54SX5S	RS	135 (62)	28¼ (718)	20¼ (514)	12¾ (324)	16½ (419)	13 (330)	13¾ (346.1)	3 (76)
15	240	68.0	3	5	LDH68SX3S	RS	195 (89)	28¼ (718)	20¼ (514)	15¾ (400)	19½ (495)	16 (406)	17¾ (454.0)	3 (76)
15	480	68.0	1	3	LDH68SX11S	RS	195 (89)	28¼ (718)	20¼ (514)	15¾ (400)	19½ (495)	16 (406)	17¾ (454.0)	3 (76)
15	480	68.0	3	5	LDH68SX5S	RS	195 (89)	28¼ (718)	20¼ (514)	15¾ (400)	19½ (495)	16 (406)	17¾ (454.0)	3 (76)
18	240	80.0	3	6	LDH80SX3S	RS	205 (93)	28¼ (718)	20¼ (514)	18¾ (476)	22½ (572)	19 (483)	20¾ (530.2)	3 (76)
18	480	80.0	1	6	LDH80SX11S	RS	205 (93)	28¼ (718)	20¼ (514)	18¾ (476)	22½ (572)	19 (483)	20¾ (530.2)	3 (76)
18	480	80.0	3	3	LDH80SX5S	RS	205 (93)	28¼ (718)	20¼ (514)	18¾ (476)	22½ (572)	19 (483)	20¾ (530.2)	3 (76)
21	240	95.0	3	7	LDH95SX3S	RS	235 (107)	28¼ (718)	20¼ (514)	21¾ (552)	25½ (648)	22 (559)	23¾ (606.4)	3 (76)
21	480	95.0	1	7	LDH95SX11S	RS	235 (107)	28¼ (718)	20¼ (514)	21¾ (552)	25½ (648)	22 (559)	23¾ (606.4)	3 (76)
21	480	95.0	3	7	LDH95SX5S	RS	235 (107)	28¼ (718)	20¼ (514)	21¾ (552)	25½ (648)	22 (559)	23¾ (606.4)	3 (76)
21	240	120.0	3	7	LDH120SX3S	RS	260 (118)	33 (838)	25 (635)	21¾ (552)	25½ (648)	22 (559)	23¾ (606.4)	3 (76)
21	480	120.0	1	7	LDH120SX11S	RS	260 (118)	33 (838)	25 (635)	21¾ (552)	25½ (648)	22 (559)	23¾ (606.4)	3 (76)
21	480	120.0	3	7	LDH120SX5S	RS	260 (118)	33 (838)	25 (635)	21¾ (552)	25½ (648)	22 (559)	23¾ (606.4)	3 (76)
21	480	160.0	3	7	LDH160SX5S	RS	290 (132)	40¾ (1029)	32¾ (826)	21¾ (552)	25½ (648)	22 (559)	23¾ (606.4)	3 (76)
21	480	200.0	3	7	LDH200SX5S	S	310 (141)	49¾ (1257)	41¾ (1054)	21¾ (552)	25½ (648)	22 (559)	23¾ (606.4)	3 (76)
24	480	225.0	3	8	LDH225SX5S	S	330 (150)	49¾ (1257)	41¾ (1054)	24¾ (629)	28¾ (724)	25 (635)	26¾ (682.6)	3 (76)

RAPID SHIP

- RS - Next day shipment up to 2 pieces
- S - 10 days lead time

Notes:

- See Watt Density vs. Air Temperature/Velocity charts on page 429 to confirm suitability in the application.

■ Truck Shipment only

Air Heaters

Duct Heaters

D SERIES



Application: High Temperature Air 800°F (427°C)

- Removable Incoloy® WATROD elements
 - Without thermostat
 - General purpose enclosure
 - Steel flange
- ① 6 and 12 element heaters have (1) 1 inch NPT conduit opening; 18, 24, 30 and 42 element heaters have (2) 1 inch NPT conduit openings; 36, 48, 54 and 60 element heaters have (2) 1 inch NPT and (2) 1¼ inch conduit openings
- ② All flanges are 12 inches wide

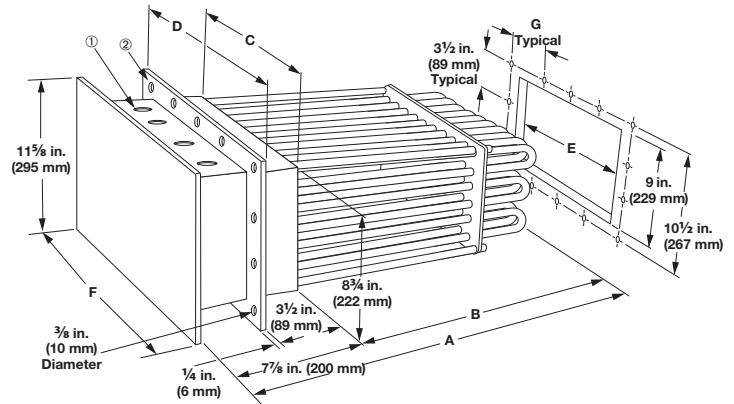

# of Elem.	Volts	kW	Ph	# Circ	Code Number	Del.	Ship Wt. lbs. (kg)	"A" Dim. in. (mm)	"B" Dim. in. (mm)	"C" Dim. in. (mm)	"D" Dim. in. (mm)	"E" Dim. in. (mm)	"F" Dim. in. (mm)	"G" Dim. in. (mm)
20 W/in² (3.1 W/cm²)														
6	240	6.0	1	1	D6S10S	RS	50 (23)	27 1/2 (708)	20 (508)	2 3/4 (70)	6 1/2 (165)	3 (76)	5 3/4 (146)	2 1/2 (64)
6	240	6.0	3	1	D6S3S	RS	50 (23)	27 1/2 (708)	20 (508)	2 3/4 (70)	6 1/2 (165)	3 (76)	5 3/4 (146)	2 1/2 (64)
6	480	6.0	1	1	D6S11S	RS	50 (23)	27 1/2 (708)	20 (508)	2 3/4 (70)	6 1/2 (165)	3 (76)	5 3/4 (146)	2 1/2 (64)
6	480	6.0	3	1	D6S5S	RS	50 (23)	27 1/2 (708)	20 (508)	2 3/4 (70)	6 1/2 (165)	3 (76)	5 3/4 (146)	2 1/2 (64)
12	240	12.0	1	1	D12S10S	RS	55 (25)	27 1/2 (708)	20 (508)	4 3/4 (121)	8 3/4 (215)	5 (127)	7 3/4 (197)	3 1/2 (89)
12	240	12.0	3	1	D12S3S	RS	55 (25)	27 1/2 (708)	20 (508)	4 3/4 (121)	8 3/4 (215)	5 (127)	7 3/4 (197)	3 1/2 (89)
12	480	12.0	1	1	D12S11S	RS	55 (25)	27 1/2 (708)	20 (508)	4 3/4 (121)	8 3/4 (215)	5 (127)	7 3/4 (197)	3 1/2 (89)
12	480	12.0	3	1	D12S5S	RS	55 (25)	27 1/2 (708)	20 (508)	4 3/4 (121)	8 3/4 (215)	5 (127)	7 3/4 (197)	3 1/2 (89)
18	240	18.0	1	2	D18S10S	RS	65 (30)	27 1/2 (708)	20 (508)	6 3/4 (171)	10 1/2 (267)	7 (178)	9 3/4 (248)	3 1/2 (89)
18	240	18.0	3	1	D18S3S	RS	65 (30)	27 1/2 (708)	20 (508)	6 3/4 (171)	10 1/2 (267)	7 (178)	9 3/4 (248)	3 1/2 (89)
18	480	18.0	1	1	D18S11S	RS	65 (30)	27 1/2 (708)	20 (508)	6 3/4 (171)	10 1/2 (267)	7 (178)	9 3/4 (248)	3 1/2 (89)
18	480	18.0	3	1	D18S5S	RS	65 (30)	27 1/2 (708)	20 (508)	6 3/4 (171)	10 1/2 (267)	7 (178)	9 3/4 (248)	3 1/2 (89)
24	240	24.0	1	2	D24S10S	RS	95 (43)	27 1/2 (708)	20 (508)	8 3/4 (222)	12 1/2 (318)	9 (229)	11 1/4 (298)	2 3/4 (70)
24	240	24.0	3	2	D24S3S	RS	95 (43)	27 1/2 (708)	20 (508)	8 3/4 (222)	12 1/2 (318)	9 (229)	11 1/4 (298)	2 3/4 (70)
24	480	24.0	1	1	D24S11S	RS	95 (43)	27 1/2 (708)	20 (508)	8 3/4 (222)	12 1/2 (318)	9 (229)	11 1/4 (298)	2 3/4 (70)
24	480	24.0	3	1	D24S5S	RS	95 (43)	27 1/2 (708)	20 (508)	8 3/4 (222)	12 1/2 (318)	9 (229)	11 1/4 (298)	2 3/4 (70)
30	240	30.0	3	2	D30S3S	RS	120 (55)	27 1/2 (708)	20 (508)	10 3/4 (273)	14 1/2 (368)	11 (279)	13 3/4 (349)	3 3/4 (83)
30	480	30.0	1	2	D30S11S	RS	120 (55)	27 1/2 (708)	20 (508)	10 3/4 (273)	14 1/2 (368)	11 (279)	13 3/4 (349)	3 3/4 (83)
30	480	30.0	3	1	D30S5S	RS	120 (55)	27 1/2 (708)	20 (508)	10 3/4 (273)	14 1/2 (368)	11 (279)	13 3/4 (349)	3 3/4 (83)

CONTINUED

RAPID SHIP

- RS - Next day shipment up to 2 pieces
- S - 10 days lead time

Notes:

- See Watt Density vs. Air Temperature/Velocity charts on page 429 to confirm suitability in the application.
- Truck Shipment only

Air Heaters

Duct Heaters

D SERIES



Application: High Temperature Air 800°F (427°C)

- Removable Incoloy® WATROD elements
- Without thermostat
- General purpose enclosure
- Steel flange

- ① 6 and 12 element heaters have (1) 1 inch NPT conduit opening; 18, 24, 30 and 42 element heaters have (2) 1 inch NPT conduit openings; 36, 48, 54, and 60 element heaters have (2) 1 inch NPT and (2) 1¼ inch conduit openings
- ② All flanges are 12 inches wide

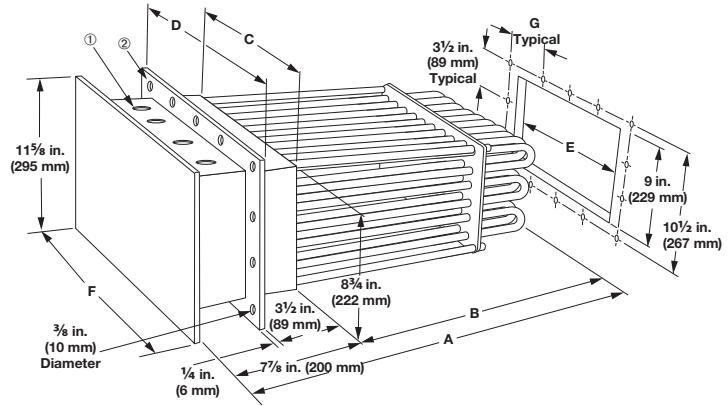

# of Elem.	Volts	kW	Ph	# Circ	Code Number	Del.	Ship Wt. lbs. (kg)	"A" Dim. in. (mm)	"B" Dim. in. (mm)	"C" Dim. in. (mm)	"D" Dim. in. (mm)	"E" Dim. in. (mm)	"F" Dim. in. (mm)	"G" Dim. in. (mm)
20 W/in² (3.1 W/cm²)														
36	240	36.0	3	2	D36S3S	RS	135 (62)	27 7/8 (708.0)	20 (508)	12 3/4 (324)	16 1/2 (419)	13 (330)	15 3/4 (400)	3 3/8 (95)
36	480	36.0	1	2	D36S11S	RS	135 (62)	27 7/8 (708.0)	20 (508)	12 3/4 (324)	16 1/2 (419)	13 (330)	15 3/4 (400)	3 3/8 (95)
36	480	36.0	3	1	D36S5S	RS	135 (62)	27 7/8 (708.0)	20 (508)	12 3/4 (324)	16 1/2 (419)	13 (330)	15 3/4 (400)	3 3/8 (95)
42	240	42.0	3	2	D42S3S	RS	155 (71)	27 7/8 (708.0)	20 (508)	14 3/4 (375)	18 1/2 (470)	15 (381)	17 3/4 (451)	4 1/4 (108)
42	480	42.0	1	2	D42S11S	RS	155 (71)	27 7/8 (708.0)	20 (508)	14 3/4 (375)	18 1/2 (470)	15 (381)	17 3/4 (451)	4 1/4 (108)
42	480	42.0	3	2	D42S5S	RS	155 (71)	27 7/8 (708.0)	20 (508)	14 3/4 (375)	18 1/2 (470)	15 (381)	17 3/4 (451)	4 1/4 (108)
48	240	48.0	3	4	D48S3S	RS	195 (89)	27 7/8 (708.0)	20 (508)	16 3/4 (425)	20 1/2 (521)	17 (432)	19 3/4 (502)	4 3/4 (121)
48	480	48.0	1	2	D48S11S	RS	195 (89)	27 7/8 (708.0)	20 (508)	16 3/4 (425)	20 1/2 (521)	17 (432)	19 3/4 (502)	4 3/4 (121)
48	480	48.0	3	2	D48S5S	RS	195 (89)	27 7/8 (708.0)	20 (508)	16 3/4 (425)	20 1/2 (521)	17 (432)	19 3/4 (502)	4 3/4 (121)
54	240	54.0	3	3	D54S3S	RS	205 (93)	27 7/8 (708.0)	20 (508)	18 3/4 (476)	22 1/2 (572)	19 (483)	21 1/4 (552)	5 1/4 (133)
54	480	54.0	1	3	D54S11S	RS	205 (93)	27 7/8 (708.0)	20 (508)	18 3/4 (476)	22 1/2 (572)	19 (483)	21 1/4 (552)	5 1/4 (133)
54	480	54.0	3	2	D54S5S	RS	205 (93)	27 7/8 (708.0)	20 (508)	18 3/4 (476)	22 1/2 (572)	19 (483)	21 1/4 (552)	5 1/4 (133)
60	240	60.0	3	4	D60S3S	RS	235 (107)	27 7/8 (708.0)	20 (508)	20 3/4 (527)	24 1/2 (622)	21 (533)	23 3/4 (603)	5 3/4 (146)
60	480	60.0	1	4	D60S11S	RS	235 (107)	27 7/8 (708.0)	20 (508)	20 3/4 (527)	24 1/2 (622)	21 (533)	23 3/4 (603)	5 3/4 (146)
60	480	60.0	3	2	D60S5S	RS	235 (107)	27 7/8 (708.0)	20 (508)	20 3/4 (527)	24 1/2 (622)	21 (533)	23 3/4 (603)	5 3/4 (146)
60	240	75.0	3	4	D75S3S	RS	260 (118)	32 3/8 (835.0)	25 (635)	20 3/4 (527)	24 1/2 (622)	21 (533)	23 3/4 (603)	5 3/4 (146)
60	480	75.0	1	4	D75S11S	RS	260 (118)	32 3/8 (835.0)	25 (635)	20 3/4 (527)	24 1/2 (622)	21 (533)	23 3/4 (603)	5 3/4 (146)
60	480	75.0	3	2	D75S5S	RS	260 (118)	32 3/8 (835.0)	25 (635)	20 3/4 (527)	24 1/2 (622)	21 (533)	23 3/4 (603)	5 3/4 (146)
60	480	100.0	3	4	D100S5S	S	290 (132)	40 3/8 (1025.5)	32 1/2 (826)	20 3/4 (527)	24 1/2 (622)	21 (533)	23 3/4 (603)	5 3/4 (146)
60	480	125.0	3	4	D125S5S	S	310 (141)	49 3/8 (1254.1)	41 1/2 (1054)	20 3/4 (527)	24 1/2 (622)	21 (533)	23 3/4 (603)	5 3/4 (146)

RAPID SHIP

- RS - Next day shipment up to 2 pieces
- S - 10 days lead time

Notes:

- See Watt Density vs. Air Temperature/Velocity charts on page 429 to confirm suitability in the application.
- Truck Shipment only

Air Heaters

Duct Heaters

D SERIES



Application: Medium Temperature Air 750°F (399°C)

- Removable Incoloy® WATROD elements
- Without thermostat
- General purpose enclosure
- Steel flange

- ① 6 and 12 element heaters have (1) 1 inch NPT conduit opening; 18, 24, 30 and 42 element heaters have (2) 1 inch NPT conduit openings; 36, 48, 54, and 60 element heaters have (2) 1 inch NPT and (2) 1¼ inch conduit openings
- ② All flanges are 12 inches wide

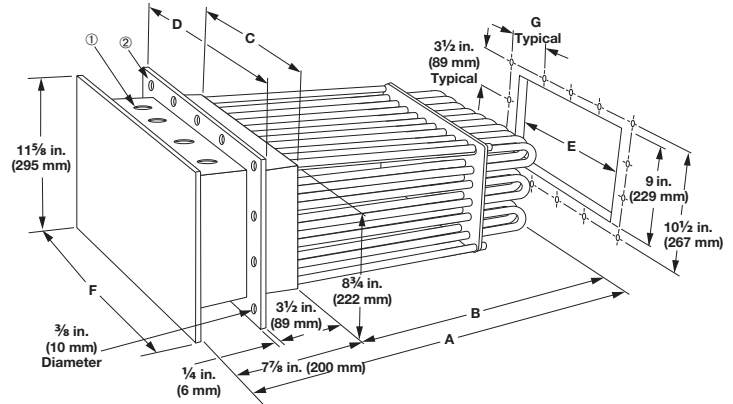

# of Elem.	Volts	kW	Ph	# Circ	Code Number	Del.	Ship Wt. lbs. (kg)	"A" Dim. in. (mm)	"B" Dim. in. (mm)	"C" Dim. in. (mm)	"D" Dim. in. (mm)	"E" Dim. in. (mm)	"F" Dim. in. (mm)	"G" Dim. in. (mm)
30 W/in² (4.7 W/cm²)														
6	240	9.0	1	1	D6SX10S	RS	50 (23)	27½ (708)	20 (508)	2¼ (70)	6½ (165)	3 (76)	5¼ (146)	2½ (64)
6	240	9.0	3	1	D6SX3S	RS	50 (23)	27½ (708)	20 (508)	2¼ (70)	6½ (165)	3 (76)	5¼ (146)	2½ (64)
6	480	9.0	1	1	D6SX11S	RS	50 (23)	27½ (708)	20 (508)	2¼ (70)	6½ (165)	3 (76)	5¼ (146)	2½ (64)
6	480	9.0	3	1	D6SX5S	RS	50 (23)	27½ (708)	20 (508)	2¼ (70)	6½ (165)	3 (76)	5¼ (146)	2½ (64)
12	240	18.0	1	2	D12SX10S	RS	55 (25)	27½ (708)	20 (508)	4¼ (121)	8½ (215)	5 (127)	7¼ (197)	3½ (89)
12	240	18.0	3	1	D12SX3S	RS	55 (25)	27½ (708)	20 (508)	4¼ (121)	8½ (215)	5 (127)	7¼ (197)	3½ (89)
12	480	18.0	1	1	D12SX11S	RS	55 (25)	27½ (708)	20 (508)	4¼ (121)	8½ (215)	5 (127)	7¼ (197)	3½ (89)
12	480	18.0	3	1	D12SX5S	RS	55 (25)	27½ (708)	20 (508)	4¼ (121)	8½ (215)	5 (127)	7¼ (197)	3½ (89)
18	240	27.0	1	3	D18SX10S	RS	65 (30)	27½ (708)	20 (508)	6¼ (171)	10½ (267)	7 (178)	9¼ (248)	3½ (89)
18	240	27.0	3	2	D18SX3S	RS	65 (30)	27½ (708)	20 (508)	6¼ (171)	10½ (267)	7 (178)	9¼ (248)	3½ (89)
18	480	27.0	1	2	D18SX11S	RS	65 (30)	27½ (708)	20 (508)	6¼ (171)	10½ (267)	7 (178)	9¼ (248)	3½ (89)
18	480	27.0	3	1	D18SX5S	RS	65 (30)	27½ (708)	20 (508)	6¼ (171)	10½ (267)	7 (178)	9¼ (248)	3½ (89)
24	240	36.0	1	4	D24SX10S	RS	95 (43)	27½ (708)	20 (508)	8¼ (222)	12½ (318)	9 (229)	11¼ (298)	2¼ (70)
24	240	36.0	3	2	D24SX3S	RS	95 (43)	27½ (708)	20 (508)	8¼ (222)	12½ (318)	9 (229)	11¼ (298)	2¼ (70)
24	480	36.0	1	2	D24SX11S	RS	95 (43)	27½ (708)	20 (508)	8¼ (222)	12½ (318)	9 (229)	11¼ (298)	2¼ (70)
24	480	36.0	3	1	D24SX5S	RS	95 (43)	27½ (708)	20 (508)	8¼ (222)	12½ (318)	9 (229)	11¼ (298)	2¼ (70)
30	240	45.0	3	5	D30SX3S	RS	120 (55)	27½ (708)	20 (508)	10¼ (273)	14½ (368)	11 (279)	13¼ (349)	3¼ (83)
30	480	45.0	1	2	D30SX11S	RS	120 (55)	27½ (708)	20 (508)	10¼ (273)	14½ (368)	11 (279)	13¼ (349)	3¼ (83)
30	480	45.0	3	2	D30SX5S	RS	120 (55)	27½ (708)	20 (508)	10¼ (273)	14½ (368)	11 (279)	13¼ (349)	3¼ (83)

CONTINUED

RAPID SHIP

- **RS** - Next day shipment up to 2 pieces
- **S** - 10 days lead time

Notes:

- See Watt Density vs. Air Temperature/Velocity charts on page 429 to confirm suitability in the application.
- Truck Shipment only

Air Heaters

Duct Heaters

D SERIES



Application: Medium Temperature Air 750°F (399°C)

- Removable Incoloy® WATROD elements
- Without thermostat
- General purpose enclosure
- Steel flange

- ① 6 and 12 element heaters have (1) 1 inch NPT conduit opening; 18, 24, 30 and 42 element heaters have (2) 1 inch NPT conduit openings; 36, 48, 54, and 60 element heaters have (2) 1 inch. NPT and (2) 1¼ inch conduit openings
- ② All flanges are 12 inches. wide

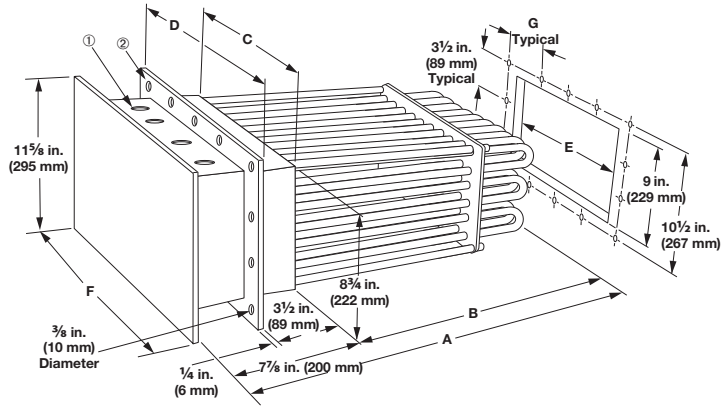

# of Elem.	Volts	kW	Ph	# Circ	Code Number	Del.	Ship Wt. lbs. (kg)	"A" Dim. in. (mm)	"B" Dim. in. (mm)	"C" Dim. in. (mm)	"D" Dim. in. (mm)	"E" Dim. in. (mm)	"F" Dim. in. (mm)	"G" Dim. in. (mm)
30 W/in² (4.7 W/cm²)														
36	240	54.0	3	3	D36SX3S	RS	135 (62)	27 7/8 (708.0)	20 (508)	12 3/4 (324)	16 1/2 (419)	13 (330)	15 3/4 (400)	3 3/4 (95)
36	480	54.0	1	3	D36SX11S	RS	135 (62)	27 7/8 (708.0)	20 (508)	12 3/4 (324)	16 1/2 (419)	13 (330)	15 3/4 (400)	3 3/4 (95)
36	480	54.0	3	2	D36SX5S	RS	135 (62)	27 7/8 (708.0)	20 (508)	12 3/4 (324)	16 1/2 (419)	13 (330)	15 3/4 (400)	3 3/4 (95)
42	240	63.0	3	7	D42SX3S	RS	155 (71)	27 7/8 (708.0)	20 (508)	14 3/4 (375)	18 1/2 (470)	15 (381)	17 3/4 (451)	4 1/4 (108)
42	480	63.0	1	3	D42SX11S	RS	155 (71)	27 7/8 (708.0)	20 (508)	14 3/4 (375)	18 1/2 (470)	15 (381)	17 3/4 (451)	4 1/4 (108)
42	480	63.0	3	2	D42SX5S	RS	155 (71)	27 7/8 (708.0)	20 (508)	14 3/4 (375)	18 1/2 (470)	15 (381)	17 3/4 (451)	4 1/4 (108)
48	240	72.0	3	4	D48SX3S	RS	195 (89)	27 7/8 (708.0)	20 (508)	16 3/4 (425)	20 1/2 (521)	17 (432)	19 3/4 (502)	4 3/4 (121)
48	480	72.0	1	4	D48SX11S	RS	195 (89)	27 7/8 (708.0)	20 (508)	16 3/4 (425)	20 1/2 (521)	17 (432)	19 3/4 (502)	4 3/4 (121)
48	480	72.0	3	2	D48SX5S	RS	195 (89)	27 7/8 (708.0)	20 (508)	16 3/4 (425)	20 1/2 (521)	17 (432)	19 3/4 (502)	4 3/4 (121)
54	240	81.0	3	6	D54SX3S	RS	205 (93)	27 7/8 (708.0)	20 (508)	18 3/4 (476)	22 1/2 (572)	19 (483)	21 3/4 (552)	5 1/4 (133)
54	480	81.0	1	6	D54SX11S	RS	205 (93)	27 7/8 (708.0)	20 (508)	18 3/4 (476)	22 1/2 (572)	19 (483)	21 3/4 (552)	5 1/4 (133)
54	480	81.0	3	3	D54SX5S	RS	205 (93)	27 7/8 (708.0)	20 (508)	18 3/4 (476)	22 1/2 (572)	19 (483)	21 3/4 (552)	5 1/4 (133)
60	240	90.0	3	5	D60SX3S	RS	235 (107)	27 7/8 (708.0)	20 (508)	20 3/4 (527)	24 1/2 (622)	21 (533)	23 3/4 (603)	5 3/4 (146)
60	480	90.0	1	4	D60SX11S	RS	235 (107)	27 7/8 (708.0)	20 (508)	20 3/4 (527)	24 1/2 (622)	21 (533)	23 3/4 (603)	5 3/4 (146)
60	480	90.0	3	4	D60SX5S	RS	235 (107)	27 7/8 (708.0)	20 (508)	20 3/4 (527)	24 1/2 (622)	21 (533)	23 3/4 (603)	5 3/4 (146)
60	240	115.0	3	10	D75SX3S	RS	260 (118)	32 3/8 (835.0)	25 (635)	20 3/4 (527)	24 1/2 (622)	21 (533)	23 3/4 (603)	5 3/4 (146)
60	480	115.0	1	5	D75SX11S	RS	260 (118)	32 3/8 (835.0)	25 (635)	20 3/4 (527)	24 1/2 (622)	21 (533)	23 3/4 (603)	5 3/4 (146)
60	480	115.0	3	4	D75SX5S	RS	260 (118)	32 3/8 (835.0)	25 (635)	20 3/4 (527)	24 1/2 (622)	21 (533)	23 3/4 (603)	5 3/4 (146)
60	480	150.0	3	4	D100SX5S	RS	290 (132)	40 3/8 (1025.5)	32 3/8 (826)	20 3/4 (527)	24 1/2 (622)	21 (533)	23 3/4 (603)	5 3/4 (146)
60	480	190.0	3	5	D125SX5S	RS	310 (141)	49 3/8 (1254.1)	41 1/2 (1054)	20 3/4 (527)	24 1/2 (622)	21 (533)	23 3/4 (603)	5 3/4 (146)

RAPID SHIP

- RS - Next day shipment up to 2 pieces
- S - 10 days lead time

Notes:

- See Watt Density vs. Air Temperature/Velocity charts on page 429 to confirm suitability in the application.
- Truck Shipment only

Air Heaters

Duct Heaters

LDH SERIES and D SERIES

Replacement Elements

Replaceable heating elements provide easy field service and reduce downtime. Element change-out is made simple by a single screw clamp.

To order replacement elements, specify the **replacement element code number** (from the table) that corresponds to the original Watlow duct heater code number. Then, specify **quantity**.

Replacement Elements

Original Duct Heater Code Numbers	Replacement Element		A Dimension		Replacement Element Code Number	Delivery	Est. Net Wt.	
	Volts	Watts	in.	(mm)			lbs	(kg)
20 W/in² (3.1 W/cm²)								
D6S3 to D60S3	240	1000	27%	(708.0)	D6240	RS	1.0	(0.5)
D6S5 to D60S5	480	1000	27%	(708.0)	D6480	RS	1.0	(0.5)
D75S3	240	1250	32%	(835.0)	D75240	RS	1.0	(0.5)
D75S5	480	1250	32%	(835.0)	D75480	RS	1.0	(0.5)
D100S5	480	1667	40%	(1025.5)	D100480	RS	1.4	(0.7)
D125S5	480	2083	49%	(1254.1)	D125480	RS	1.7	(0.8)
30 W/in² (4.7 W/cm²)								
D6SX3 to D60SX3	240	1500	27%	(708.0)	D6X240	RS	1.0	(0.5)
D6SX5 to D60SX5	480	1500	27%	(708.0)	D6X480	RS	1.0	(0.5)
D75SX3	240	1917	32%	(835.0)	D75X240	RS	1.0	(0.5)
D75SX5	480	1917	32%	(835.0)	D75X480	RS	1.0	(0.5)
D100SX5	480	2500	40%	(1025.5)	D100X480	RS	1.4	(0.7)
D125SX5	480	3167	49%	(1254.1)	D125X480	RS	1.7	(0.8)

RAPID SHIP

- RS - Same day shipment up to 15 pieces

Air Heaters

Duct Heaters

LDH SERIES and D SERIES

Ordering Information

To order, complete the code number to the right with the information below:

Example: D6SX10 S J HJ

Stock Duct Code Number ① _____

Optional Terminal Enclosures ② _____

S = General purpose enclosure
W = Moisture resistant enclosure

Optional Process Sensor _____

PJ = Type J process thermocouple in thermowell
PK = Type K process thermocouple in thermowell

Sheath Limit Sensor _____

HJ = Type J high-limit thermocouple
HK = Type K high-limit thermocouple

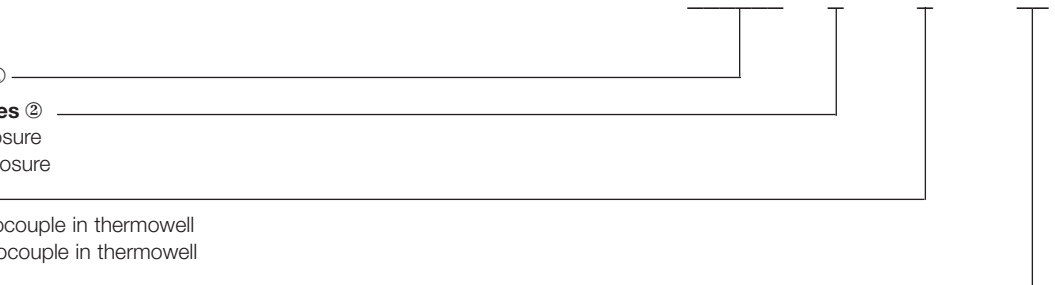

① Catalog code numbers include optional enclosures. To order optional enclosures or sensors, substitute the appropriate suffix.

② Catalog listing is a general purpose enclosure. Substitute enclosure options are noted.

Air Heaters

Duct Heaters

MDH SERIES

Watlow has developed a line of process air heaters offering improved performance and increased versatility in medium to low temperature applications.

The duct heaters are modular and consist of two parts. The first is a 6 kilowatts heater available in either 240 or 480 volts, single- or three-phase.

The second part of the heater consists of the electrical housing protecting each module's termination area and a main flange that bolts into the user's ductwork. The heater modules are installed in the housing and main flange via rectangular slots in the main flange. The range of modules that can be accommodated in various duct heater assemblies, range from 1-10 modules. A range of 6 to 60 kilowatts, in 6 kilowatt increments is achieved.

The new design of the modular duct heater offers increased reliability. The individual modules are removable through the housing of the assembly, which eliminates the need to pull the complete heater from the ductwork. This reduces downtime and costs because the heating elements can be replaced individually.

Performance improvements include quicker response time and reduced infiltration from the air stream being heated into the electrical enclosure.

Features and Benefits

Individual modules removable through housing

- Reduces downtime for replacement of module

27 percent reduction in heat-up time as compared to traditional 0.430 inch diameter duct heater elements

- Results in faster response time

Smaller diameter elements (0.315 inch)

- Results in a 25 percent lower energy usage on initial heat-up

31 percent lighter weight than traditional tubular duct heaters

- Reduces shipping costs and increases worker safety

Greater free cross sectional area

- Results in lower pressure drop

Improved seal between element and electrical housing

- Results in lower electrical housing temperature

Flexible module wiring

- Allows user to sequentially stage modules

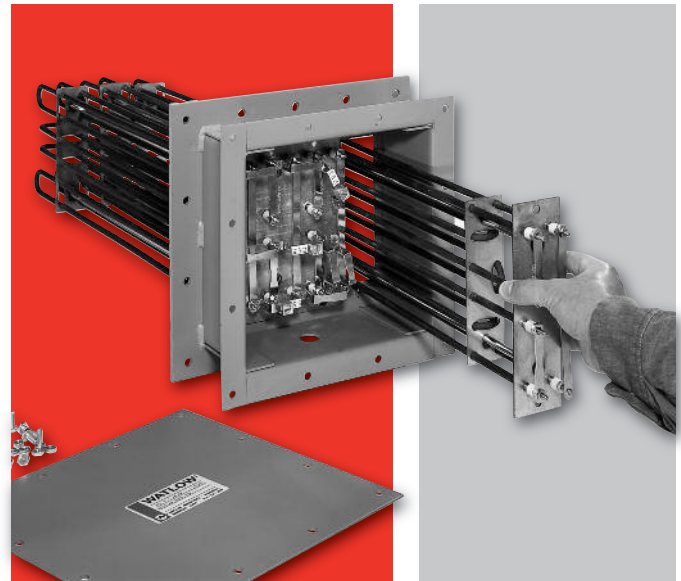

Typical Applications

- Low temperature ovens
- Parts drying
- Semiconductor clean room environmental heating
- Plastic curing
- Load banks
- Heated air knives
- Food dehydration
- Heat shrink tunnels

RAPID SHIP

- Same day shipment up to 2 pieces

Air Heaters

Duct Heaters

MDH SERIES

Velocity vs. Process Temperature

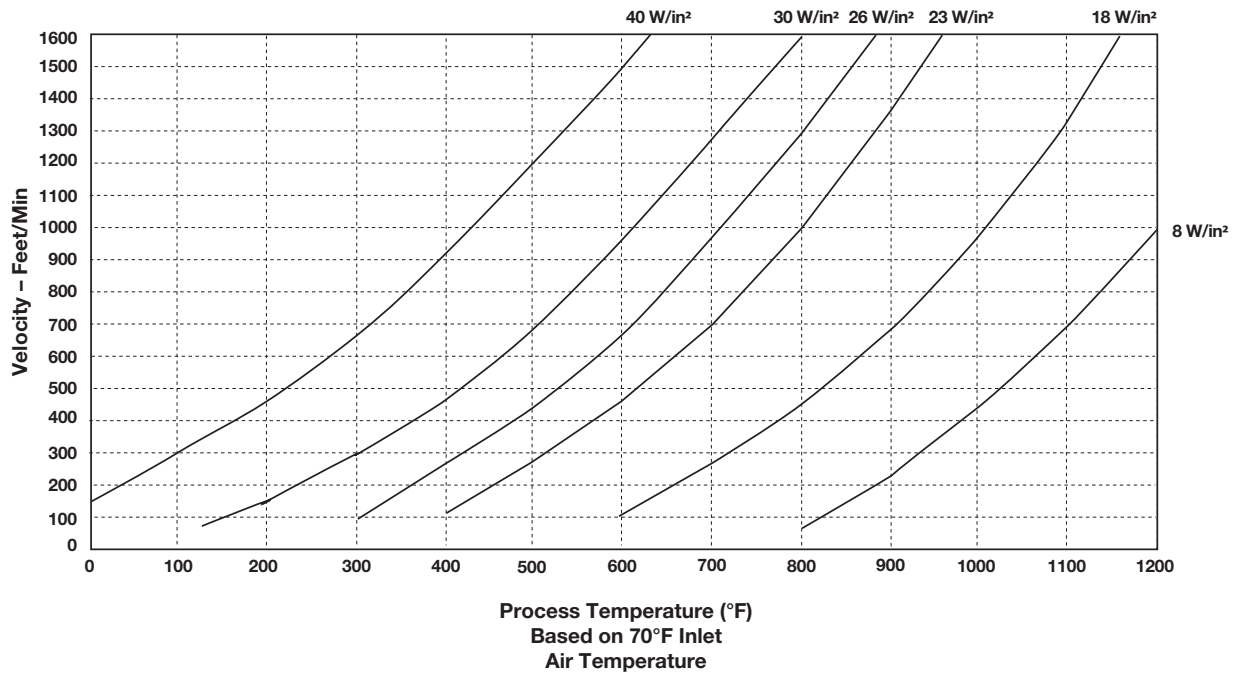

Watt Density vs. Sheath Temperature

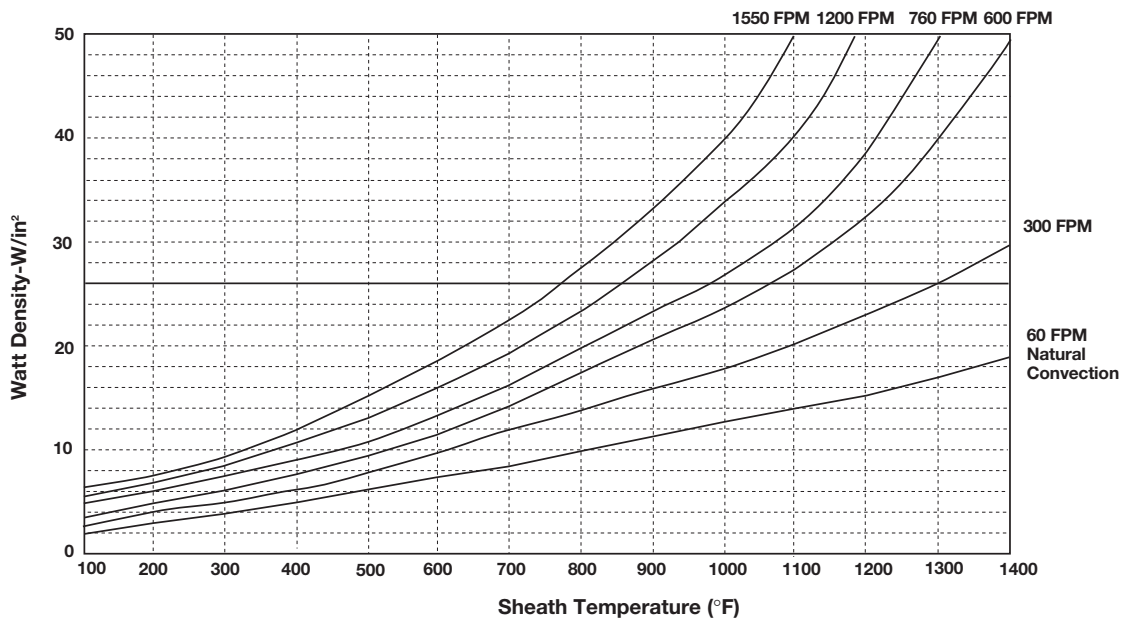

Air Heaters

Duct Heaters

MDH SERIES

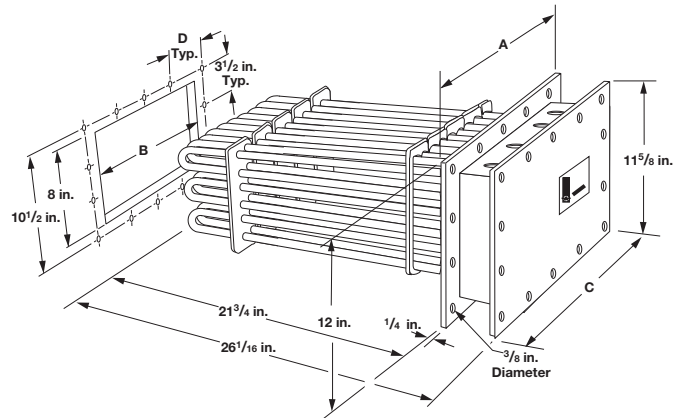

Application: Air Heating – Maximum outlet temperature – 750°F (399°C)

Watt Density W/in ²	kW	Volts	Phase	No. of Circuits	No. of Modules	Est. Shipping Wt. lbs	Del.	Code Number	Dimensions in.			
									A	B	C	D
26	6	240	1	1	1	35	RS	MDH6S10	6.50	2.50	5.75	2.50
26	6	240	3	1	1	35	RS	MDH6S3	6.50	2.50	5.75	2.50
26	6	480	1	1	1	35	RS	MDH6S11	6.50	2.50	5.75	2.50
26	6	480	3	1	1	35	RS	MDH6S5	6.50	2.50	5.75	2.50
26	12	240	1	2	2	39	RS	MDH12S10	8.50	4.75	7.75	3.50
26	12	240	3	1	2	39	RS	MDH12S3	8.50	4.75	7.75	3.50
26	12	480	1	1	2	39	RS	MDH12S11	8.50	4.75	7.75	3.50
26	12	480	3	1	2	39	RS	MDH12S5	8.50	4.75	7.75	3.50
26	18	240	1	3	3	46	RS	MDH18S10	10.50	7.00	9.75	3.00
26	18	240	3	1	3	46	RS	MDH18S3	10.50	7.00	9.75	3.00
26	18	480	1	1	3	46	RS	MDH18S11	10.50	7.00	9.75	3.00
26	18	480	3	1	3	46	RS	MDH18S5	10.50	7.00	9.75	3.00
26	24	240	1	4	4	67	RS	MDH24S10	12.50	9.25	11.75	2.75
26	24	240	3	2	4	67	RS	MDH24S3	12.50	9.25	11.75	2.75
26	24	480	1	2	4	67	RS	MDH24S11	12.50	9.25	11.75	2.75
26	24	480	3	1	4	67	RS	MDH24S5	12.50	9.25	11.75	2.75
26	30	240	3	2	5	84	RS	MDH30S3	15.75	11.50	15.00	3.56
26	30	480	1	2	5	84	RS	MDH30S11	15.75	11.50	15.00	3.56
26	30	480	3	1	5	84	RS	MDH30S5	15.75	11.50	15.00	3.56
26	36	240	3	2	6	95	RS	MDH36S3	18.00	13.75	17.25	4.13
26	36	480	1	2	6	95	RS	MDH36S11	18.00	13.75	17.25	4.13
26	36	480	3	1	6	95	RS	MDH36S5	18.00	13.75	17.25	4.13
26	42	240	3	3	7	109	RS	MDH42S3	20.25	16.00	19.50	4.69
26	42	480	1	3	7	109	RS	MDH42S11	20.25	16.00	19.50	4.69
26	42	480	3	2	7	109	RS	MDH42S5	20.25	16.00	19.50	4.69
26	48	240	3	4	8	137	RS	MDH48S3	22.50	18.25	21.75	5.25
26	48	480	1	3	8	137	RS	MDH48S11	22.50	18.25	21.75	5.25
26	48	480	3	2	8	137	RS	MDH48S5	22.50	18.25	21.75	5.25
26	54	240	3	3	9	144	RS	MDH54S3	24.75	20.50	24.00	5.81
26	54	480	1	3	9	144	RS	MDH54S11	24.75	20.50	24.00	5.81
26	54	480	3	2	9	144	RS	MDH54S5	24.75	20.50	24.00	5.81
26	60	240	3	4	10	165	RS	MDH60S3	27.00	22.75	26.25	6.38
26	60	480	1	4	10	165	RS	MDH60S11	27.00	22.75	26.25	6.38
26	60	480	3	2	10	165	RS	MDH60S5	27.00	22.75	26.25	6.38

Options include individual modules with optional NEMA 1 housing, high-temperature thermocouple kit and blank flange modules.

Modular duct heaters with **1** and **2** modules have conduit openings for **one**, 1 inch NPT fitting.

Modular duct heaters with **3, 4, 5,** and **7** modules have conduit openings for **two**, 1 inch NPT fittings.

Modular duct heaters with **6, 8, 9,** and **10** modules have conduit openings for **two**, 1 1/4 inch NPT and **two**, 1 inch NPT fittings.

■ Truck Shipment only

RAPID SHIP

• RS - Same day shipment up to 2 pieces

Air Heaters

Duct Heaters

MDH SERIES

Individual Module Dimensions

Specifications

- Module rating - 240 or 480VAC, 6kW, three-phase or one-phase
- Watt Density - 26 W/in²
- Elements - 0.315 inch dia. Incoloy® elements
- High-limit thermocouple installed by drilling premarked hole in flange
- 6-60kW range when mounted in duct heater assembly

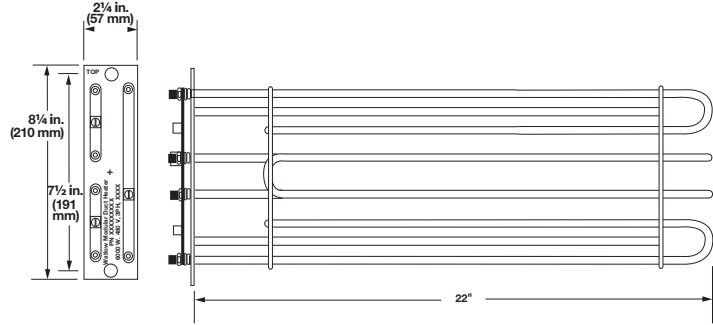

Application Information

- Maximum sheath temperature = 1200°F (649°C)
- Maximum outlet temperature = 750°F (399°C)

Options

Terminal Enclosures

Terminal enclosures are available in NEMA 1 and 4 configurations.

High-Limit Thermocouples

High-limit thermocouples can be supplied on specified modules or shipped as a kit. Available thermocouples are Types J and K.

Blank Module Covers

Module covers are available for covering blank slots on the main flange. This allows for adding heater module at a later time to allow higher wattage outputs.

Watlow Code Number	Description
Replacement Modules	
M63	6kW, 240V, 3 phase
M610	6kW, 240V, 1 phase
M65	6kW, 480V, 3 phase
M611	6kW, 480V, 1 phase
High Limit Thermocouple Kits	
MTCJ	Type J (0-1000°F)
MTCK	Type K (0-2000°F)
Blank Module Covers	
MBLK	Cover slots in main flange

Air Heaters

Finned Heaters

375 Finned Strip Heaters

Watlow's 375 finned strip is constructed of highly-compacted MgO-based insulation, which conducts heat efficiently from the nickel chromium element wire to the sheath. Two-inch wide (51 mm) aluminized steel fins are attached in a way that maximizes surface contact so heat is transferred into the air faster. Lower sheath temperature and element life are all maximized by this finned construction.

Performance Capabilities

- Aluminized steel sheath temperatures to 1100°F (595°C)
- Watt density up to 33 W/in² (5.1 W/cm²)
- UL® approved to 240VAC (File No. E52951)
- CSA approved to 600VAC (File No. LR7392)

Features and Benefits

Nickel chromium element wire is centered in the heater

- Heats the strip uniformly

Aluminized steel sheath

- Operates at higher temperatures
- Resists corrosion better than iron-sheathed heaters

Optional 430 SS sheath

- Provides a solution for more corrosive environments

Welded post terminals

- Produces strong, trouble-free connections

Available lengths from 5½ to 48 in. (140 to 1220 mm)

Typical Applications

- Enclosure heating
- Load bank resistors
- Shrink tunnels
- Duct heaters
- Space heaters
- Drying ovens
- Incubators
- Air heating
- Heat curing
- Ink drying
- Food warmers
- Moisture protection
- Dehumidifiers
- Stress relieving ovens

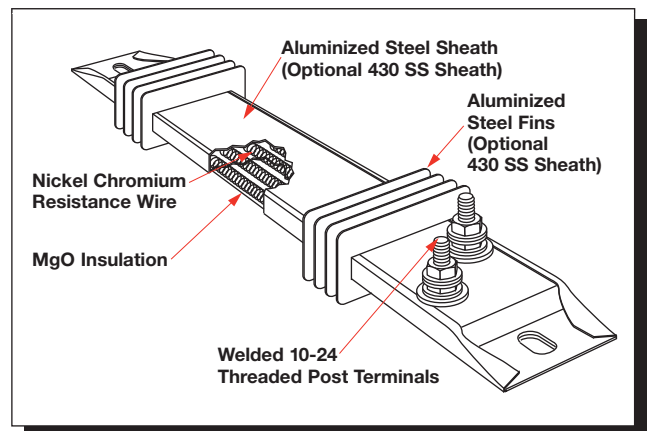

Air Heaters

Finned Heaters

375 Finned Strip Heaters

Applications and Technical Data

Calculating Watt Density

Use the graph and formulas to make certain the maximum allowable watt density for the heater will not be exceeded in the application.

Open air watt density is calculated for total heated surface area.

Formulas

$$\text{Watt Density} = \frac{\text{Wattage}}{\text{Heated Area}}$$

$$\begin{aligned} \text{Heated Area} \\ (\text{Offset Terminals}) &= [\text{Overall Length (A)} - 4 \text{ in.}] \\ &\quad \times 3.75 \text{ in.} \\ &= [\text{Overall Length (A)} - 102 \text{ mm}] \\ &\quad \times 95.3 \text{ mm} \end{aligned}$$

$$\begin{aligned} \text{Heated Area} \\ (\text{Parallel Terminals}) &= [\text{Overall Length (A)} - 3.12 \text{ in.}] \\ &\quad \times 3.75 \text{ in.} \\ &= [\text{Overall Length (A)} - 79.3 \text{ mm}] \\ &\quad \times 95.3 \text{ mm} \end{aligned}$$

$$\begin{aligned} \text{Heated Area} \\ (\text{One-on-One Terminals}) &= [\text{Overall Length (A)} - 4.25 \text{ in.}] \\ &\quad \times 3.75 \text{ in.} \\ &= [\text{Overall Length (A)} - 108 \text{ mm}] \\ &\quad \times 95.3 \text{ mm} \end{aligned}$$

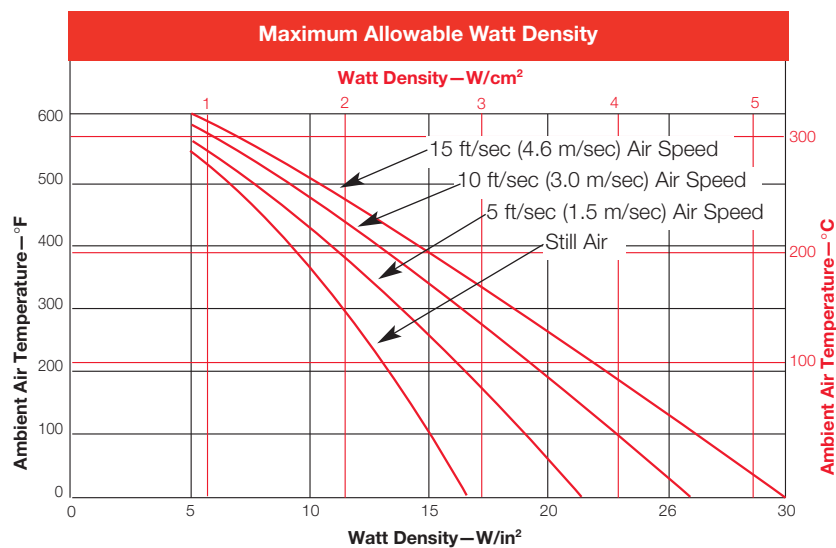

Air Heaters

Finned Heaters

375 Finned Strip Heaters

Termination Options

Offset Terminals

Two, 10-24 threaded post terminals are offset from each other on the same end.

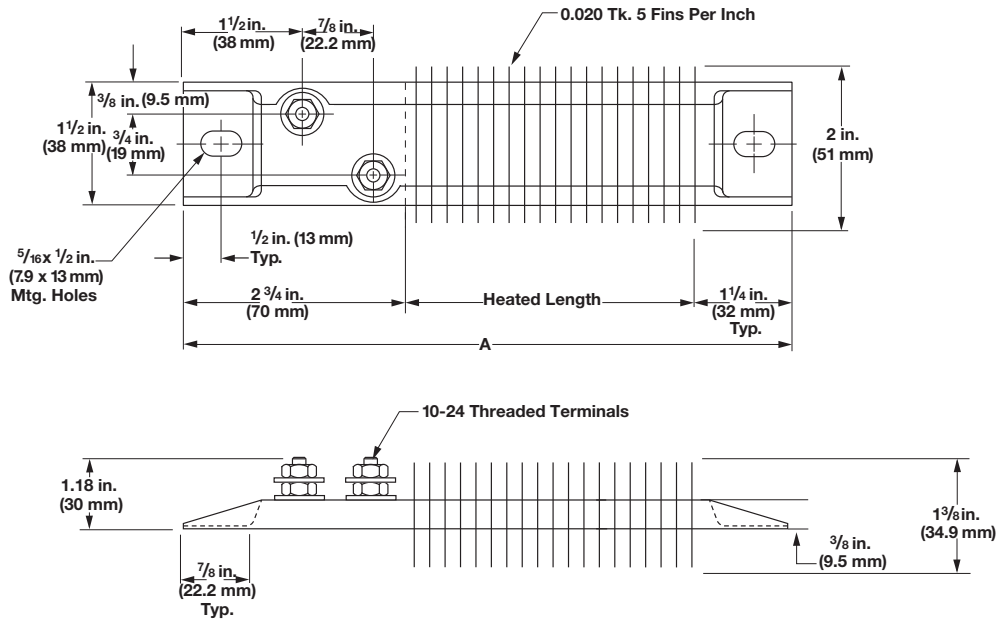

Parallel Terminals

Two, 10-24 threaded post terminals are used; both terminals on one end.

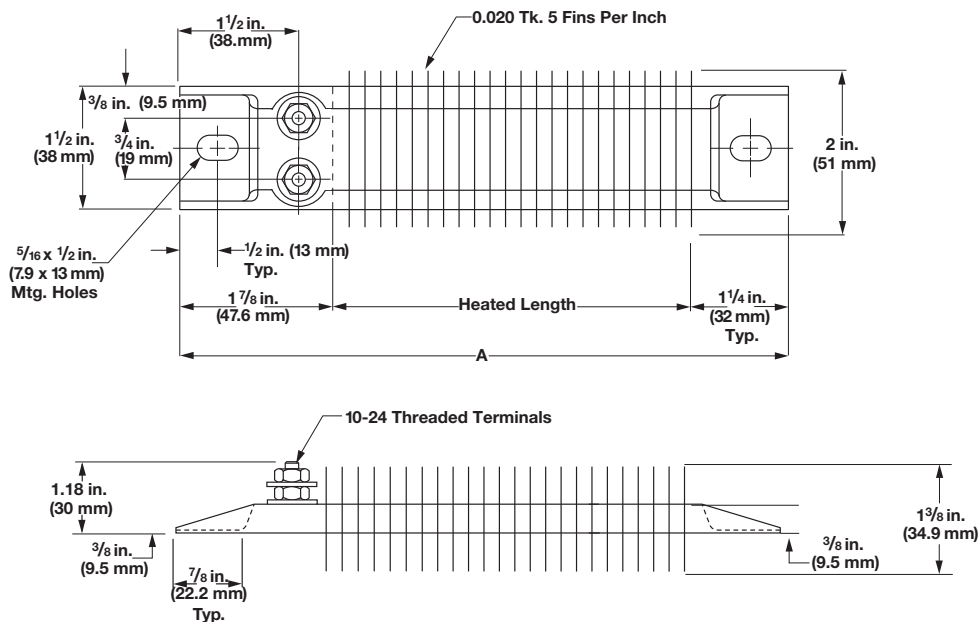

Air Heaters

Finned Heaters

375 Finned Strip Heaters

Termination Options (Continued)

One-on-One Terminals

Two, 10-24 threaded post terminals are used; one terminal on each end.

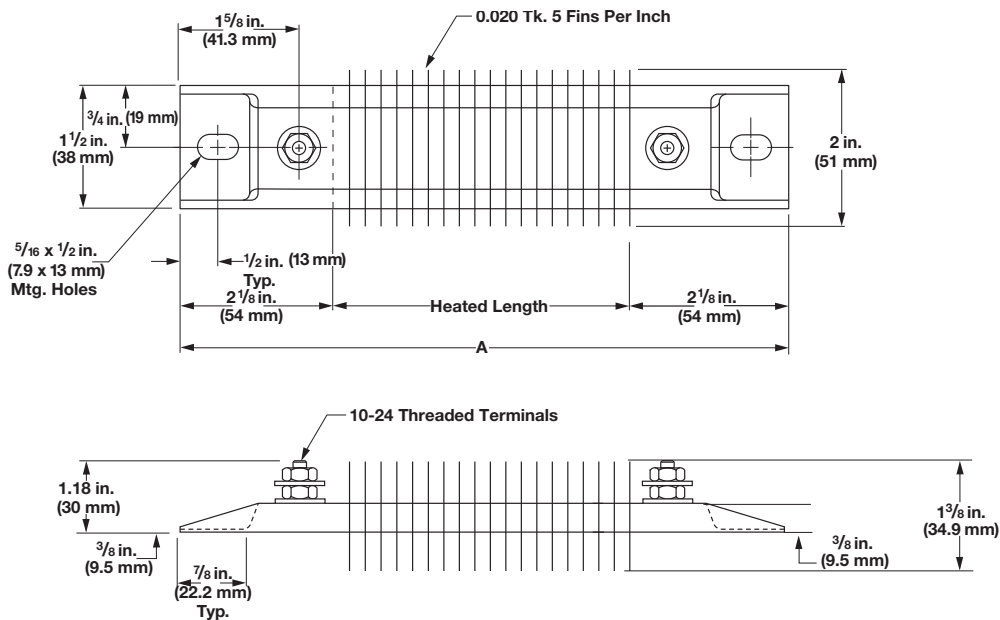

Accessories

Secondary Insulation Bushings

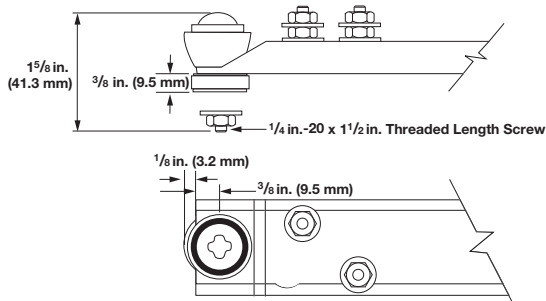

Insulators are suitable for use when air heating and/or voltage to ground is a concern. Secondary insulation bushing kit part number **Z-5230** contains one set of bushings for one heater. To accommodate the bushings, $1\frac{1}{2} \times 1\frac{1}{16}$ inch diameter mounting holes **must** be specified when ordering.

Ceramic Terminal Covers

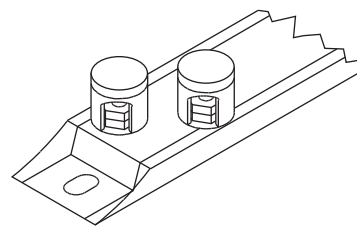

A convenient and economical way to insulate post terminals. Sized for standard length posts. 10-24 screw thread size. These are supplied as an accessory item and shipped separately. Specify **Z-4918** and quantity.

Air Heaters

Finned Heaters

375 Finned Strip Heaters

Heater Code Numbers

Width in. (mm)	Termination	Length in. (mm)	Volts	Power (Watts)	W/in ² (W/cm ²)	Approx. Net Wt. lbs (kg)	Delivery	Code Number
1½ (38)	Parallel	5½ (140)	120	125	14 (2.1)	0.5 (0.23)	Assy. Stock	SGA1J5JY2
	Parallel	5½ (140)	120	250	28 (4.3)	0.5 (0.23)	Assy. Stock	SGA1J5JY3
	Parallel	6 (152)	120	150	14 (2.1)	0.5 (0.23)	Assy. Stock	SGA1J6AY1
	Parallel	6 (152)	240	150	14 (2.1)	0.5 (0.23)	Assy. Stock	SGA1J6AY2
	Parallel	6 (152)	120	300	28 (4.3)	0.5 (0.23)	Assy. Stock	SGA1J6AY3
	Parallel	6 (152)	240	300	28 (4.3)	0.5 (0.23)	Assy. Stock	SGA1J6AY4
	Offset	7½ (191)	120	150	12 (1.8)	0.7 (0.32)	Assy. Stock	SGA1J7JW1
	Offset	7½ (191)	240	150	12 (1.8)	0.7 (0.32)	Standard	SGA1J7JW2
	Offset	7½ (191)	240	200	15 (2.3)	0.7 (0.32)	Assy. Stock	SGA1J7JW3
	Offset	8 (203)	120	150	10 (1.5)	0.7 (0.32)	Assy. Stock	SGA1J8AW2
	Offset	8 (203)	240	150	10 (1.5)	0.7 (0.32)	Assy. Stock	SGA1J8AW3
	Offset	8 (203)	120	175	12 (1.8)	0.7 (0.32)	Assy. Stock	SGA1J8AW4
	Offset	8 (203)	240	175	12 (1.8)	0.7 (0.32)	Standard	SGA1J8AW5
	Offset	8 (203)	120	250	17 (2.6)	0.7 (0.32)	Assy. Stock	SGA1J8AW6
	Offset	8 (203)	240	250	17 (2.6)	0.7 (0.32)	Assy. Stock	SGA1J8AW7
	Offset	8 (203)	120	400	27 (4.2)	0.7 (0.32)	Assy. Stock	SGA1J8AW8
	Offset	8 (203)	240	400	27 (4.2)	0.7 (0.32)	Assy. Stock	SGA1J8AW9
	Offset	8 (203)	120	500	33 (5.1)	0.7 (0.32)	Assy. Stock	SGA1J8AW10
	Offset	8 (203)	240	500	33 (5.1)	0.7 (0.32)	Assy. Stock	SGA1J8AW11
	Offset	10½ (267)	120	250	10 (1.5)	0.9 (0.40)	Assy. Stock	SGA1J10JW1
	Offset	10½ (267)	240	250	10 (1.5)	0.9 (0.40)	Assy. Stock	SGA1J10JW2
	Offset	10½ (267)	120	350	14 (2.1)	0.9 (0.40)	Assy. Stock	SGA1J10JW3
	Offset	10½ (267)	240	350	14 (2.1)	0.9 (0.40)	Assy. Stock	SGA1J10JW4
	Offset	10½ (267)	120	400	16 (2.5)	0.9 (0.40)	Assy. Stock	SGA1J10JW5
	Offset	10½ (267)	240	400	16 (2.5)	0.9 (0.40)	Assy. Stock	SGA1J10JW6
	Offset	12 (305)	120	250	8 (1.2)	1.0 (0.45)	Assy. Stock	SGA1J12AW1
	Offset	12 (305)	240	250	8 (1.2)	1.0 (0.45)	Assy. Stock	SGA1J12AW2
	Offset	12 (305)	120	350	12 (1.8)	1.0 (0.45)	Assy. Stock	SGA1J12AW3
	Offset	12 (305)	240	350	12 (1.8)	1.0 (0.45)	Assy. Stock	SGA1J12AW4
	Offset	12 (305)	120	500	17 (2.6)	1.0 (0.45)	Assy. Stock	SGA1J12AW5
	Offset	12 (305)	240	500	17 (2.6)	1.0 (0.45)	Assy. Stock	SGA1J12AW6
	Offset	14 (356)	120	300	8 (1.2)	1.2 (0.54)	Assy. Stock	SGA1J14AW1
	Offset	14 (356)	240	300	8 (1.2)	1.2 (0.54)	Assy. Stock	SGA1J14AW2
	Offset	14 (356)	120	500	13 (2.0)	1.2 (0.54)	Assy. Stock	SGA1J14AW3
	Offset	14 (356)	240	500	13 (2.0)	1.2 (0.54)	Assy. Stock	SGA1J14AW4
	Offset	15¼ (387)	120	325	8 (1.2)	1.4 (0.64)	Assy. Stock	SGA1J15EW1
	Offset	15¼ (387)	240	325	8 (1.2)	1.4 (0.64)	Assy. Stock	SGA1J15EW2
	Offset	15¼ (387)	240	500	12 (1.8)	1.4 (0.64)	Assy. Stock	SGA1J15EW3

CONTINUED

- Assembly stock delivery, 3 working days
- Standard stock delivery, 1 working day

Note: 375 finned strip heaters with one-on-one terminations are available only as a manufactured item. Please contact your Watlow representative for additional information.

Note: 5/16 x 1/2 in. (7.9 x 13 mm) mounting slots are supplied on all 375 finned strip heaters. Tabs can be removed upon request.

Air Heaters

Finned Heaters

375 Finned Strip Heaters

Heater Code Numbers (Continued)

Width in. (mm)	Termination	Length in. (mm)	Volts	Power (Watts)	W/in ² (W/cm ²)	Approx. Net Wt. lbs (kg)	Delivery	Code Number
1½ (38)	Offset	17½ (454)	120	350	8 (1.2)	1.6 (0.73)	Assy. Stock	SGA1J17RW1
	Offset	17½ (454)	240	350	8 (1.2)	1.6 (0.73)	Standard	SGA1J17RW2
	Offset	17½ (454)	120	375	9 (1.4)	1.6 (0.73)	Standard	SGA1J17RW3
	Offset	17½ (454)	240	375	9 (1.4)	1.6 (0.73)	Assy. Stock	SGA1J17RW4
	Offset	17½ (454)	120	500	12 (1.8)	1.6 (0.73)	Assy. Stock	SGA1J17RW5
	Offset	17½ (454)	240	500	12 (1.8)	1.6 (0.73)	Assy. Stock	SGA1J17RW6
	Offset	17½ (454)	120	750	18 (2.8)	1.6 (0.73)	Assy. Stock	SGA1J17RW7
	Offset	17½ (454)	240	750	18 (2.8)	1.6 (0.73)	Assy. Stock	SGA1J17RW8
	Offset	17½ (454)	120	1000	24 (3.7)	1.6 (0.73)	Assy. Stock	SGA1J17RW9
	Offset	17½ (454)	240	1000	24 (3.7)	1.6 (0.73)	Assy. Stock	SGA1J17RW10
	Offset	19½ (495)	240	350	6 (.9)	1.7 (0.77)	Assy. Stock	SGA1J19JW2
	Offset	19½ (495)	120	500	9 (1.4)	1.7 (0.77)	Standard	SGA1J19JW3
	Offset	19½ (495)	240	500	9 (1.4)	1.7 (0.77)	Assy. Stock	SGA1J19JW4
	Offset	19½ (495)	240	750	13 (2.0)	1.7 (0.77)	Assy. Stock	SGA1J19JW5
	Offset	19½ (495)	240	1000	17 (2.6)	1.7 (0.77)	Assy. Stock	SGA1J19JW6
	Offset	21 (533)	120	500	8 (1.2)	1.9 (0.86)	Standard	SGA1J21AW3
	Offset	21 (533)	240	500	8 (1.2)	1.9 (0.86)	Assy. Stock	SGA1J21AW4
	Offset	21 (533)	120	750	12 (1.8)	1.9 (0.86)	Assy. Stock	SGA1J21AW5
	Offset	21 (533)	240	750	12 (1.8)	1.9 (0.86)	Assy. Stock	SGA1J21AW6
	Offset	23¾ (603)	240	500	7 (1.0)	2.1 (0.95)	Assy. Stock	SGA1J23NW3
	Offset	23¾ (603)	240	750	10 (1.5)	2.1 (0.95)	Standard	SGA1J23NW5
	Offset	23¾ (603)	120	1000	14 (2.1)	2.1 (0.95)	Assy. Stock	SGA1J23NW6
	Offset	23¾ (603)	240	1000	14 (2.1)	2.1 (0.95)	Assy. Stock	SGA1J23NW7
	Offset	23¾ (603)	240	1500	20 (3.1)	2.1 (0.95)	Assy. Stock	SGA1J23NW8
	Offset	25½ (648)	120	500	6 (0.9)	2.3 (1.00)	Assy. Stock	SGA1J25JW2
	Offset	25½ (648)	240	500	6 (0.9)	2.3 (1.00)	Assy. Stock	SGA1J25JW3
	Offset	25½ (648)	120	750	9 (1.4)	2.3 (1.00)	Standard	SGA1J25JW4
	Offset	25½ (648)	240	750	9 (1.4)	2.3 (1.00)	Assy. Stock	SGA1J25JW5
	Offset	25½ (648)	240	1000	12 (1.8)	2.3 (1.00)	Assy. Stock	SGA1J25JW6
	Offset	26¾ (680)	240	700	8 (1.2)	2.4 (1.10)	Assy. Stock	SGA1J26NW2
	Offset	26¾ (680)	240	1000	12 (1.8)	2.4 (1.10)	Assy. Stock	SGA1J26NW3
	Offset	30½ (775)	120	750	8 (1.2)	2.7 (1.20)	Standard	SGA1J30JW1
	Offset	30½ (775)	240	750	8 (1.2)	2.7 (1.20)	Assy. Stock	SGA1J30JW2
	Offset	33½ (851)	240	750	7 (1.0)	3.0 (1.40)	Assy. Stock	SGA1J33JW1
	Offset	35½ (911)	120	1000	8 (1.2)	3.2 (1.50)	Standard	SGA1J35RW1
	Offset	35½ (911)	240	1000	8 (1.2)	3.2 (1.50)	Assy. Stock	SGA1J35RW2
	Offset	35½ (911)	240	1500	13 (2.0)	3.2 (1.50)	Assy. Stock	SGA1J35RW3
	Offset	38½ (978)	120	1000	8 (1.2)	3.4 (1.50)	Standard	SGA1J38JW2
	Offset	38½ (978)	240	1500	11 (1.7)	3.4 (1.50)	Assy. Stock	SGA1J38JW3
	Offset	42½ (1080)	240	1500	10 (1.5)	3.8 (1.70)	Assy. Stock	SGA1J42JW1
	Offset	47% (1216)	240	2250	16 (2.4)	4.3 (2.00)	Assy. Stock	SGA1J47RW2

- Assembly stock delivery, 3 working days
- Standard stock delivery, 1 working day

Note: 375 finned strip heaters with one-on-one terminations are available only as a manufactured item. Please contact your Watlow representative for additional information.

Note: ⅝ x ½ in. (7.9 x 13 mm) mounting slots are supplied on all 375 finned strip heaters. Tabs can be removed upon request.

Air Heaters

Finned Heaters

FINBAR Single/Double-Ended Heaters

Composed of aluminized steel fins press fitted to a one-inch single-ended FIREBAR® element. The FINBAR is designed to improve heat transfer to the air and permits putting more power in tighter spaces—like forced air ducts, dryers, ovens and load bank resistors.

Heat transfer, lower sheath temperature and element life are all maximized by its finned construction.

Installation is simplified by terminations exiting at one end and mounting accommodations on both ends.

Features and Benefits

Rugged aluminized steel fins

- Provides an increase in surface area to approximately 16 square inches for every linear inch of element length. Fins press fitted to the heating element improve heat transfer to the air

Single-ended termination

- Simplifies wiring and installation

Stainless steel mounting bracket, welded to the terminal end, supplied with a slotted end

- Allows ease of installation

Lavacone seals

- Provides protection against humid storage conditions, moisture retardant to 392°F (200°C)

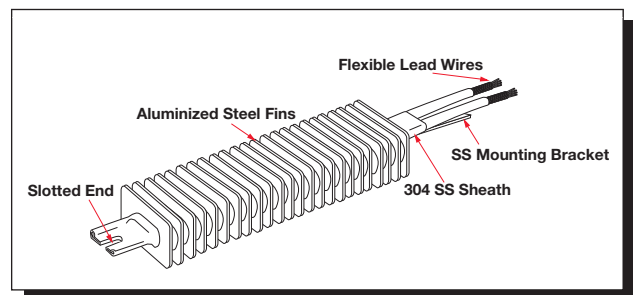
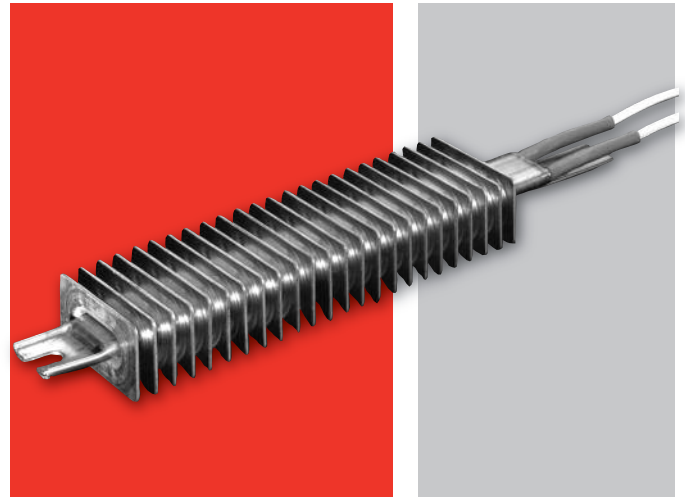

For detailed product and ordering information, see the full FINBAR product section located on pages 110 through 112.

Air Heaters

FIREROD® Cartridge Heaters

Watlow FIREROD® cartridge heaters revolutionized the heating element industry in 1954 when it was patented as the first swaged cartridge heater. The mechanical procedure of swaging reduces the diameter of the heater by compacting the unit; this directly improves the heat transfer and efficiency of the heater.

FIREROD cartridge heaters are built using only the finest materials and construction methods and are backed with extensive quality assurance programs. With premium materials and tight manufacturing controls, the FIREROD heater provides superior heat transfer, uniform temperatures, resistance to oxidation and corrosion and a long life even at high temperatures.

FIREROD offers many delivery programs to meet your needs.

Performance Capabilities

- Watt densities up to 100 W/in² (15.5 W/cm²)
- Maximum voltage up to 480V
- Contact Watlow for maximum part temperatures

Features and Benefits

Nickel-chromium resistance wire

- Assures even and efficient distribution of heat to the sheath

Conductor pins

- Provides a metallurgical bond to the resistance wire
- Ensures a trouble-free electrical connection

Magnesium oxide insulation of specific grain and purity

- Results in high dielectric strength and contributes to faster heat-up

Incoloy® sheath

- Resists oxidation and corrosion from many chemicals, heat and atmospheres

Minimal spacing between the element wire and sheath

- Results in lower internal temperature
- Accommodates a design with fewer or smaller heaters operating at higher watt densities

UL® and CSA approved flexible stranded wires

- Lead insulation rated to temperatures of 480°F (250°C)

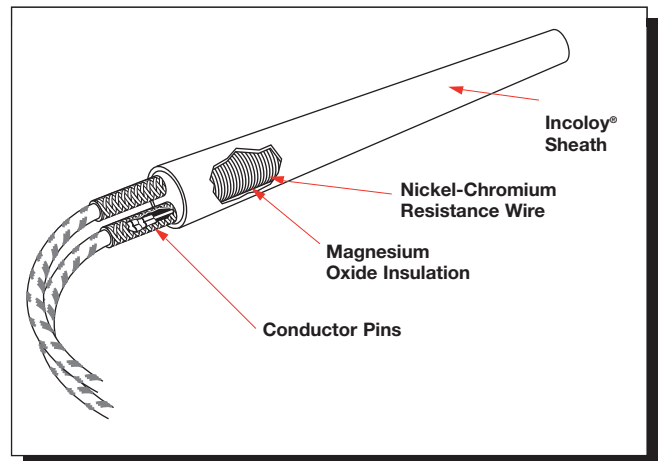
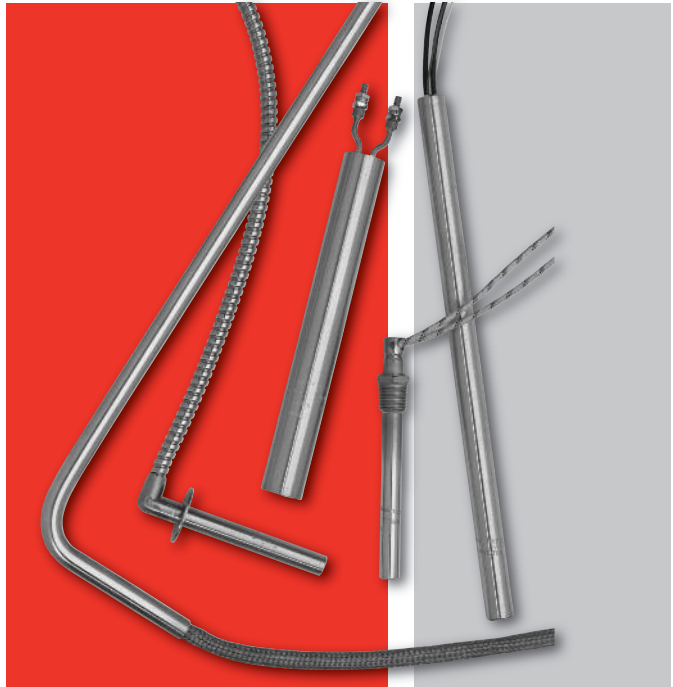

Patented lead adapter (LA) method

- Allows same day shipment on more than 150,000 configurations of stock FIREROD heaters and lead combinations

For detailed product and ordering information, see the full FIREROD® product section located on pages 9 through 45.

Air Heaters

Enclosure Heaters

WATROD Heaters

Designed to prevent freezing and condensation in electrical and mechanical housings, the WATROD element is enclosed in a perforated, aluminized-steel bracket.

Performance Capabilities

- Watt densities to 15 W/in² (2.3 W/cm²)
- Wattages to 1000 watts
- UL® and CSA component recognition to 250VAC

Features and Benefits

Stainless steel sheath wall

- Resists corrosion and protects the heating coil from exposure

Silicone resin seal

- Provides protection against humid storage conditions and is effective to 390°F (200°C)

Perforated aluminized-steel mounting bracket

- Eases installation and helps prevent direct contact with the heating element

Stock straight projection Type B #10-32 screw lug terminals

- Provides easy electrical connection

Made-to-order threaded stud

- Provides quick connect and flexible lead wire termination options.

Typical Applications

- Control panels
- Traffic signal boxes
- Automated teller machines
- Switch gear
- Electronic equipment

Application Hints

- Locate heater(s) in the lowest portion of the enclosure to maximize convection heating
- Place thermostat(s) in the upper half of the enclosure, away from the heater(s)

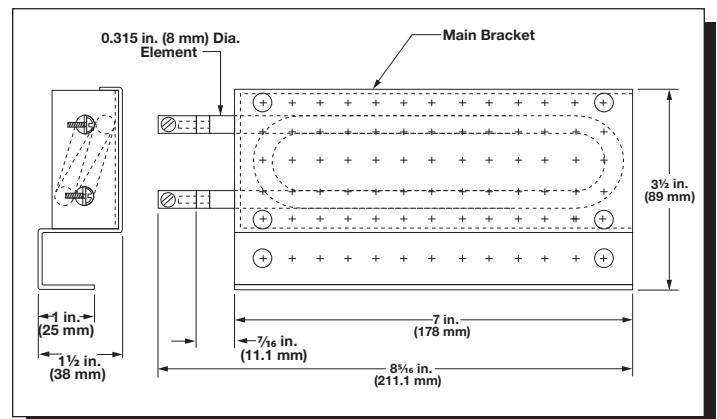
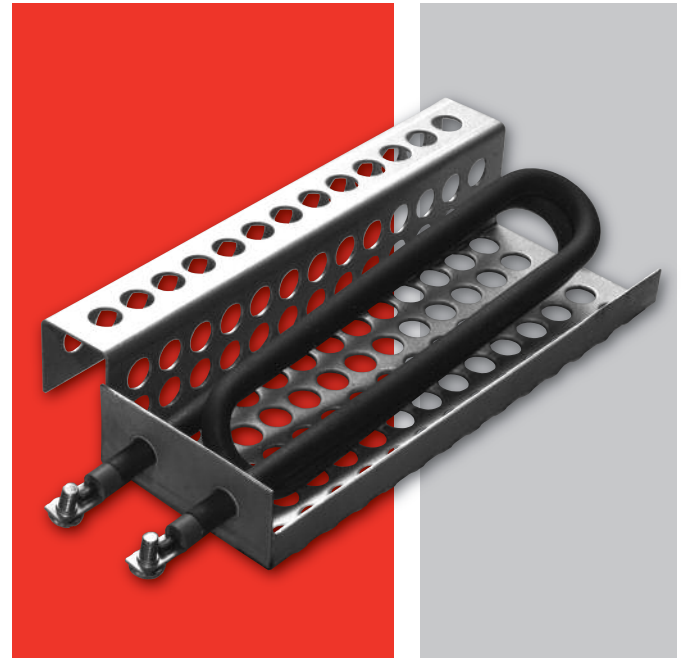

RAPID SHIP

- Same day shipment up to 15 pieces

Air Heaters

Enclosure Heaters

WATROD Heaters

Technical Information

Watts	Watt Density		Code Number		Delivery	Est. Net Wt.	
	W/in ²	(W/cm ²)	125VAC	250VAC		lbs	(kg)
95	4	(0.6)	EN951		RS	1.5	(0.7)
100	4	(0.6)		EN10010	RS	1.5	(0.7)
250	10	(1.6)	EN2501	EN25010	RS	1.5	(0.7)
375	15	(2.3)	EN3751	EN37510	RS	1.5	(0.7)

RAPID SHIP

- **RS** - Same day shipment up to 5 pieces

Air Heaters

Enclosure Heaters

Silicone Rubber Heaters

Designed for freeze and condensation protection, Watlow's enclosure heaters are rugged, reliable and safe to operate. These rectangular-shaped, wire-wound silicone rubber heaters can be ordered by themselves with adhesive or vulcanized to an aluminum mounting plate. A thermostat can be attached to the heater or mounted separately. Pictured are units with thermostat on heater in foreground and heater with remote thermostat in background.

Performance Capabilities

- Watt density rating of 5 W/in² (0.8 W/cm²)
- Temperature to 150°F (66°C)

Features and Benefits

Pressure sensitive adhesive, mounting to aluminum plate or customer cementing

- Reduces installation time
- Creates easy installation

Several standard thermostat set points

- Ensures protection against freezing with minimal energy consumption

Variety of installation options

- Provides the customer the option to utilize cement installation ensuring permanent attachment of heater
- Saves assembly time choosing the pressure sensitive adhesive installation option
- Facilitates assembly and disassembly with factory installed aluminum plate mount

Remote thermostat option

- Provides optimal choice of heater location versus temperature control location

Lead options

- Allows for a variety of applications
- Allows for different lead lengths for a variety of wiring requirements

Factory pre-wired heater and thermostat

- Ensures safety and reliability due to no exposed electrical connections

No exposed electrical connections

- Creates a safe and reliable operation

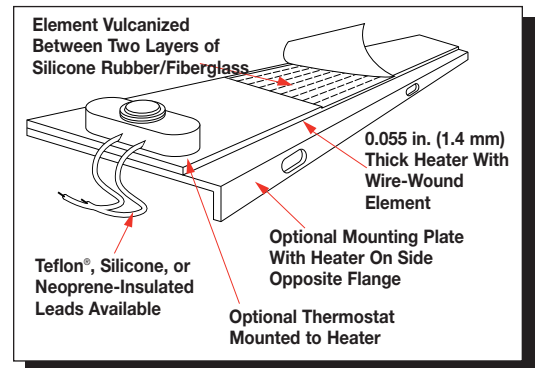
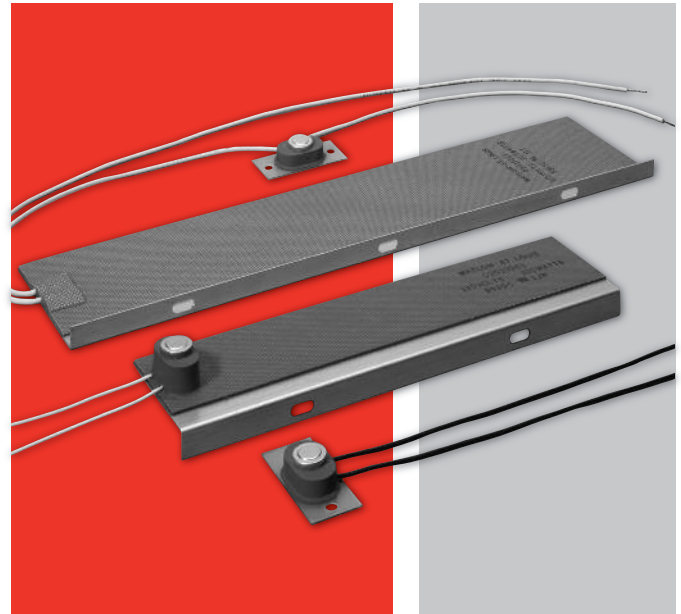

Typical Applications

Freeze or condensation prevention in housings containing electronic equipment. Examples include:

- Traffic signal boxes
- Automated teller machines
- Temperature control panels
- Gas or liquid control valve housings

Air Heaters

Enclosure Heaters

Silicone Rubber Heaters

Options

Aluminum Mounting Plate

Both vertical and horizontal mounting can be accomplished with enclosure heaters. The mounting plates are 0.040 in. (1.02 mm) thick, specified as #3003 H14 aluminum. The preferred orientation is vertical, with a thermostat attached at the lower end (as shown in the drawing).

For horizontal mounting, a remote thermostat is recommended. An enclosure heater can be ordered by itself, with PSAS or vulcanized to an aluminum mounting plate. See *Thermostats* below for more information.

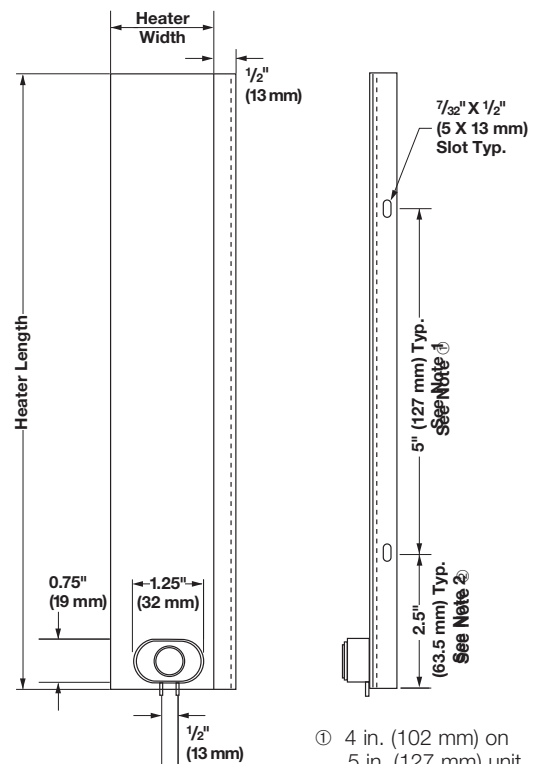
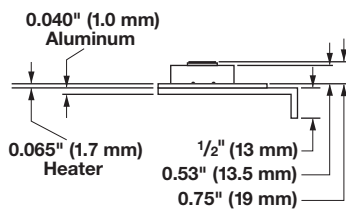

- ① 4 in. (102 mm) on 5 in. (127 mm) unit.
- ② 0.5 in. (13 mm) on 5 in. (127 mm) unit.

Thermostats

Mounted on Heater

Built-in snap action thermostats from Watlow are designed to sense air temperature. See the ordering chart on the following page for available settings.

Remote From Heater

For an air sensing thermostat separate from the heater, the ST-207E is ideal. This is a modified ST-207 mounted on a 1/2 in. (0.8 mm) thick G-10 circuit board with the thermostat's metal cap exposed to sense air temperature. The thermostat is placed at the midpoint of the lead length. The sensor can be preset at the temperatures listed for integral sensors.

Notes:

- On both integral and remote sensors, the thermostat's exposed metal cap is vulnerable to impact. This could defeat the thermostat's switching action and cause heater malfunction.
- T-10 thermostats are not recommended for enclosure heating applications.

Air Heaters

Enclosure Heaters

Silicone Rubber Heaters

Technical Data

Determining Minimum Wattage Requirements For Enclosures

This chart is an excellent guide for determining total wattage requirements for both insulated and uninsulated enclosures, assuming the box is relatively airtight.

For windy conditions, add an additional 50 percent to the wattage requirement listed.

		Total Enclosure Surface Area – Square Feet (Square Meters)													
		2 (0.2)	3 (0.3)	4 (0.4)	5 (0.5)	6 (0.6)	7.5 (0.7)	9 (0.8)	10 (0.9)	15 (1.4)	20 (1.9)	25 (2.3)	30 (2.8)	40 (3.7)	50 (4.7)
Temperature Rise from Ambient °F (°C)	20 (11)	30	40	55	70	80	100	120	135	205	270	335	405	540	670
		10	10	15	20	20	25	30	35	50	65	80	100	130	160
	40 (22)	55	80	110	135	160	200	245	270	405	540	670	805	1075	1340
		15	20	30	35	40	50	60	65	100	130	160	195	260	320
	60 (33)	90	120	160	205	245	300	365	405	605	805	1005	1210	1610	2010
		20	30	55	50	60	75	90	100	145	195	240	290	385	480
	80 (44)	110	160	215	270	325	400	485	540	805	1075	1340	1610	2145	2680
		30	40	55	65	80	100	115	130	195	260	320	385	515	640
	100 (56)	135	200	270	335	405	500	605	670	1005	1340	1675	2010	2680	3350
		35	50	65	80	100	125	145	160	240	320	400	480	640	800
	120 (67)	165	240	320	405	485	600	725	805	1210	1610	2010	2415	3220	4020
		40	60	80	100	115	150	175	195	290	385	480	580	770	960
	140 (78)	190	280	375	470	565	700	845	940	1410	1880	2345	2815	3755	4690
		45	70	90	115	135	175	205	225	340	450	560	675	900	1120

□ Uninsulated boxes □ Insulated boxes

Silicone Rubber Enclosure Heaters Offering

For a complete list of silicone rubber product offerings available for use as an enclosure heater with a thermostat, please refer to RAPID SHIP offering on page 123.

